

## REFERENCES

- American Water Works Association, AWWA Standard for Deep Wells, AWWA-A100-66, Denver, Colorado, 1967.
- Bedient, P. B., and W. C. Huber, *Hydrology and Floodplain Analysis*, 2nd ed., Reading, MA, Addison-Wesley, 1992.
- Bouwer, H., and R. C. Rice, "A Slug Test for Determining Hydraulic Conductivity of Unconfined Aquifers with Completely or Partially Penetrating Wells," *Water Resources Res.* 12:423-428, 1976.
- Campbell, M. D., and J. H. Lehr, *Water Well Technology*, New York, McGraw-Hill, 1973.
- Cooper, H. H., Jr., J. D. Bredehoeft, and I. S. Papadopoulos, "Response of a Finite-Diameter Well to an Instantaneous Charge of Water," *Water Resour. Res.*, vol. 3, pp. 263-269, 1967.
- Cooper, H. H., Jr., and C. E. Jacob, "A Generalized Graphical Method for Evaluating Formation Constants and Summarizing Well Field History," *Trans. Am. Geophys. Union*, vol. 27, pp. 526-534, 1946.
- DeWiest, R. J. M., *Geohydrology*, New York, John Wiley and Sons, Inc., 1965.
- Ferris, J. G., D. B. Knowles, R. H. Browne, and R. W. Stallman, *Theory of Aquifer Tests*, U.S. Geological Survey Water Supply Paper 1536-E, 1962.
- Freeze, R. A., and J. A. Cherry, *Ground Water*, Englewood Cliffs, New Jersey, Prentice-Hall, 1979.
- Hantush, M. S., "Analysis of Data from Pumping Tests in Leaky Aquifers," *J. Geophys. Res.*, vol. 69, pp. 4221-4235, 1956.
- Hvorslev, M. J., Time Lag and Soil Permeability in Ground Water Observations, U.S. Army Corps of Engineers Waterways Exp. Sta. Bull. 36, Vicksburg, Mississippi, 1951.
- Papadopoulos, I. S., J. D. Bredehoeft, and H. H. Cooper, Jr., "On the Analysis of Slug Test Data," *Water Resour. Res.*, vol. 9, no. 4, pp. 1087-1089, 1973.
- Theis, C. V., "The Relation Between the Lowering of the Piezometric Surface and the Rate and Duration of Discharge of a Well Using Ground-Water Storage," *Trans. Am. Geophys. Union*, vol. 16, pp. 519-524, 1935.
- Walton, W. C., Leaky Artesian Aquifer Conditions in Illinois, Illinois State Water Surv. Rept. Invest. 39, Urbana, Illinois, 1960.

## CHAPTER 4

# SOURCES AND TYPES OF GROUND WATER CONTAMINATION

## 4.1 INTRODUCTION

Humans have been exposed to hazardous substances dating back to prehistoric times when they inhaled noxious gases from volcanoes and in cave dwellings. Pollution problems started in the industrial sector with the production of dyes and other organic chemicals developed from the coal tar industry in Germany during the 1800s. In the 1900s the variety of chemicals and chemical wastes increased drastically from the production of steel and iron, lead batteries, petroleum refining, and other industrial practices. During that time radium and chromic wastes began to create serious problems as well. The World War II era ushered in massive production of wartime products that required use of chlorinated solvents, polymers, plastics, paints, metal finishing, and wood preservatives. Very little was known about the environmental impacts of many of these chemical wastes until much later.

The Love Canal hazardous waste site attracted major public attention in 1979 and heralded the hazardous waste decade of the 1980s. The site in Niagara Falls, New York, had received 20,000 metric tons of chemical waste containing at least 80 different chemicals and was creating serious environmental impacts on nearby residents. By 1989 state and federal governments had spent \$140 million to clean up the site and relocate the residents. Several other sites during the 1980s also received national attention including the Stringfellow Acid Pits near Riverside, California; the Valley of the Drums in Kentucky; the Brio and Motco chemical waste sites in Houston, Texas; the dioxin contamination at Times Beach, Missouri, and at the Vertac facility in Arkansas. Many of the above sites and dozens of others all across the United States became the subject of major environmental investigations and remediation studies under Superfund. In addition, many of the largest sites came under private or federal litigation starting in about 1986 to the present.

No hazardous waste site is more famous at the national level than the one created by poor industrial practices in Woburn, Massachusetts, where tannery wastes back to 1850 and chlorinated chemicals were dumped. The claim was made that chlorinated chemicals contaminated two drinking water wells in the small community, and may have resulted in the deaths of a number of children living in the area. The dispute over which company was responsible for the contamination of the wells resulted in a major lawsuit, a major site investigation, and the recent best-selling book and motion picture, *A Civil Action* (Harr, 1995).

This chapter describes most of the significant chemical threats to ground water quality from various sources of contamination. In a 1984 report, *Protecting the Nation's Groundwater from Contamination*, the Office of Technology Assessment (OTA 1984) listed more than 30 different potential sources of contamination. Table 4.1 lists the major sources of ground water contamination and divides them into six major categories. Section 305(b) of the Federal Clean Water Act requires states to submit reports to the EPA on sources and types of ground water contamination. In 1988 the *National Water Quality Inventory — 1988 Report to Congress* (USEPA 1990) presented the data on the relative importance of various sources of contamination and various types of contaminants. State inventories showed that more than half the states and territories listed underground storage tanks, septic tanks, agricultural activities, municipal landfills, and abandoned hazardous waste sites as major threats to ground water. Other sources that were listed include industrial landfills, injection wells, regulated hazardous waste sites, land application, road salt, salt water intrusion, and brine pits from oil and gas wells. The highest priority rankings were given to underground storage tanks, abandoned waste sites, agricultural activity, septic tanks, surface impoundments, and municipal landfills.

Table 4.2 provides a list of major organic contaminants according to the Environmental Protection Agency (EPA). This is the target list of 126 priority pollutants defined by EPA for their contract laboratory program. The volatile compounds are determined by standard EPA method 624, the semivolatiles by method 625, and pesticides and PCBs by method 608.

TABLE 4.1 Sources Of Ground Water Contamination

CATEGORY I	CATEGORY II	CATEGORY III
Sources designed to discharge substances	Sources designed to store, treat, and/or dispose of substances; discharge through unplanned release	Sources designed to retain substances during transport or transmission
Subsurface percolation (e.g., septic tanks and cesspools)	Landfills	Pipelines
Injection wells	Open dumps	Materials transport and transfer
Land application	Surface impoundments	
	Waste tailings	
	Waste piles	
	Materials stockpiles	
	Above ground storage tanks	
	Under ground storage tanks	
	Radioactive disposal sites	
CATEGORY IV	CATEGORY V	CATEGORY VI
Sources discharging as consequence of other planned activities	Sources providing conduit or inducing discharge through altered flow patterns	Naturally occurring sources whose discharge is created and/or exacerbated by human activity
Irrigation practices	Production wells	Ground water – surface water interactions
Pesticide applications	Other wells (non-waste)	Natural leaching
Fertilizer applications	Construction excavation	Salt-water intrusion/ brackish water upcoming
Animal feeding operations		
De-icing salts applications		
Urban runoff		
Percolation of atmospheric pollutants		
Mining and mine drainage		

Office of Technology Assessment, 1984

Figures 4.1 and 4.2 indicate the priority rankings of the sources and of the various contaminants as reported to Congress in 1990. Each section of this chapter discusses how the major sources of contamination may degrade ground water quality and provides the latest information about the scope of the problem. Figure 4.3 shows the various mechanisms of ground water contamination associated with some of the major sources, which include chemical and fuel storage tanks, septic tanks, municipal landfills, and surface impoundments. A wide variety of organic and inorganic chemicals have been identified as potential contaminants in ground water. These include inorganic compounds such as nitrates, brine, and various trace metals; synthetic organic chemicals such as fuels, chlorinated solvents, and pesticides; radioactive contaminants associated with defense sites; and pathogens.

Large quantities of organic compounds are manufactured and used by industry, the federal government, agriculture, and municipalities. They have created the greatest potential for ground water contamination, as described later in this chapter. One such group is the soluble aromatic hydrocarbons associated with petroleum fuels or lubricants. The group includes benzene, toluene, ethyl benzene, and various xylene isomers (BTEX) often associated with petroleum spills. Chlorinated hydrocarbons such as tetrachloroethylene (PCE) and

TABLE 4.2. Environmental Protection Agency List of Priority Pollutants

Base-Neutral Extractables		
Acenaphthene	Diethyl phthalate	
Acenaphthylene	Dimethyl phthalate	
Anthracene	2,4-Dinitrotoluene	
Benzidine	2,6-Dinitrotoluene	
Benzo[a]anthracene	Di-n-octyl phthalate	
Benzo[b]fluoranthene	1,2-Diphenylhydrazine	
Benzo[k]fluoranthene	Fluoranthene	
Benzo[ghi]perylene	Fluorene	
Benzo[a]pyrene	Hexachlorobenzene	
Bis(2-chloroethoxy) methane	Hexachlorobutadiene	
Bis(2-chloroethyl) ether	Hexachlorocyclopentadiene	
Bis(2-chloroisopropyl) ether	Hexachloroethane	
Bis(2-ethylhexyl) phthalate	Indeno[1,2,3-cd] pyrene	
4-Bromophenyl phenyl ether	Isophorone	
Butyl benzyl phthalate	Naphthalene	
2-Chloronaphthalene	Nitrobenzene	
4-Chlorophenyl phenyl ether	N-Nitrosodimethylamine	
Chrysene	N-Nitrosodiphenylamine	
Dibenzo[a,h] anthracene	N-Nitrosodi-n-propylamine	
Di-n-butyl phthalate	Phenanthrene	
1,2-Dichlorobenzene	Pyrene	
1,3-Dichlorobenzene	2,3,7,8-Tetrachlorodibenzo-p-dioxin	
1,4-Dichlorobenzene	1,2,4-Trichlorobenzene	
3,3'-Dichlorobenzidine		
Pesticides		
Aldrin	Dieldrin	PCB-1016 <sup>a</sup>
-BHC	-Endosulfan	PCB-1221 <sup>a</sup>
-BHC	-Endosulfan	PCB-1232 <sup>a</sup>
-BHC	Endosulfan sulfate	PCB-1242 <sup>a</sup>
-BHC	Endrin	PCB-1248 <sup>a</sup>
Chlordane	Endrin aldehyde	PCB-1254 <sup>a</sup>
4,4'-DDD	Heptachlor	PCB-1260 <sup>a</sup>
4,4'-DDE	Heptachlor epoxide	Toxaphene
4,4'-DDT		<sup>a</sup> not pesticides

Organic compounds are subdivided into four categories according to the method of analysis

TABLE 4.2. Environmental Protection Agency List of Priority Pollutants

Volatiles		
Acrolein	1,1-Dichloroethylene	
Acrylonitrile	trans-1,2-Dichloroethylene	
Benzene	1,2-Dichloropropane	
Bis(chloromethyl) ether	cis-1,3-Dichloropropene	
Bromodichloromethane	trans-1,3-Dichloropropene	
Bromofom	Ethylbenzene	
Bromomethane	Methylene chloride	
Carbon tetrachloride	Styrene	
Chlorobenzene	1,1,2,2-Tetrachloroethane	
Chloroethane	1,1,2,2-Tetrachloroethene	
2-Chloroethyl vinyl ether	Toluene	
Chloroform	1,1,1-Trichloroethane	
Chloromethane	1,1,2-Trichloroethane	
Dibromochloromethane	Trichloroethylene	
Dichlorodifluoromethane	Trichlorofluoromethane	
1,1-Dichloroethane	Vinyl chloride	
1,2-Dichloroethane	Xylene	
Acid Extractables		
p-Chloro-m-cresol	2-Nitrophenol	
2-Chlorophenol	4-Nitrophenol	
2,4-Dichlorophenol	Pentachlorophenol	
2,4-Dimethylphenol	Phenol	
4,6-Dinitro-o-cresol	2,4,6-Trichlorophenol	
2-4-Dinitrophenol	Total phenols	
Inorganics		
Antimony	Chromium	Nickel
Arsenic	Copper	Selenium
Asbestos	Cyanide	Silver
Beryllium	Lead	Thallium
Cadmium	Mercury	Zinc

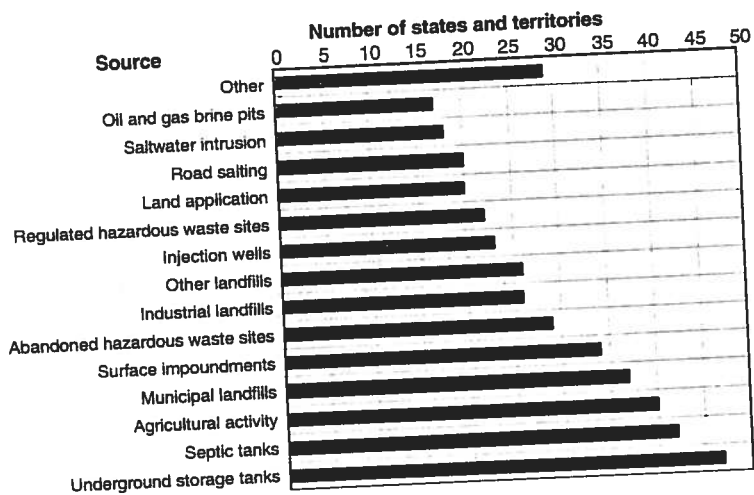

Figure 4.1 Frequency of various contamination sources considered by states and territories of the United States to be major threats to ground water quality.

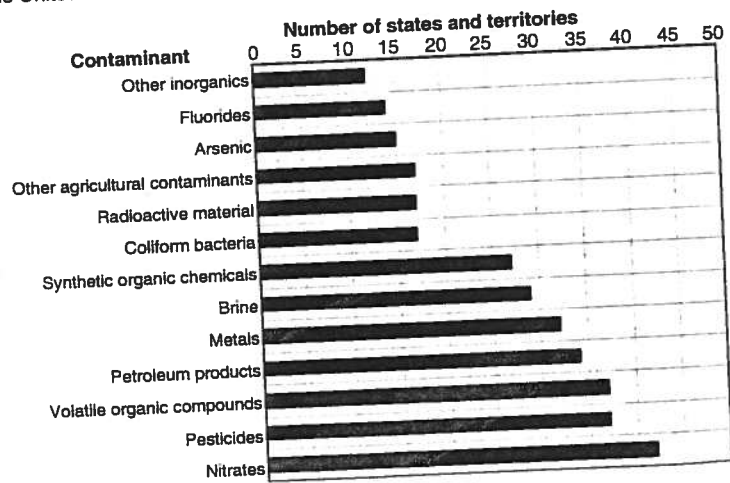

Figure 4.2 Frequency of various contaminants considered by states and territories of the United States to be major threats to ground water quality.

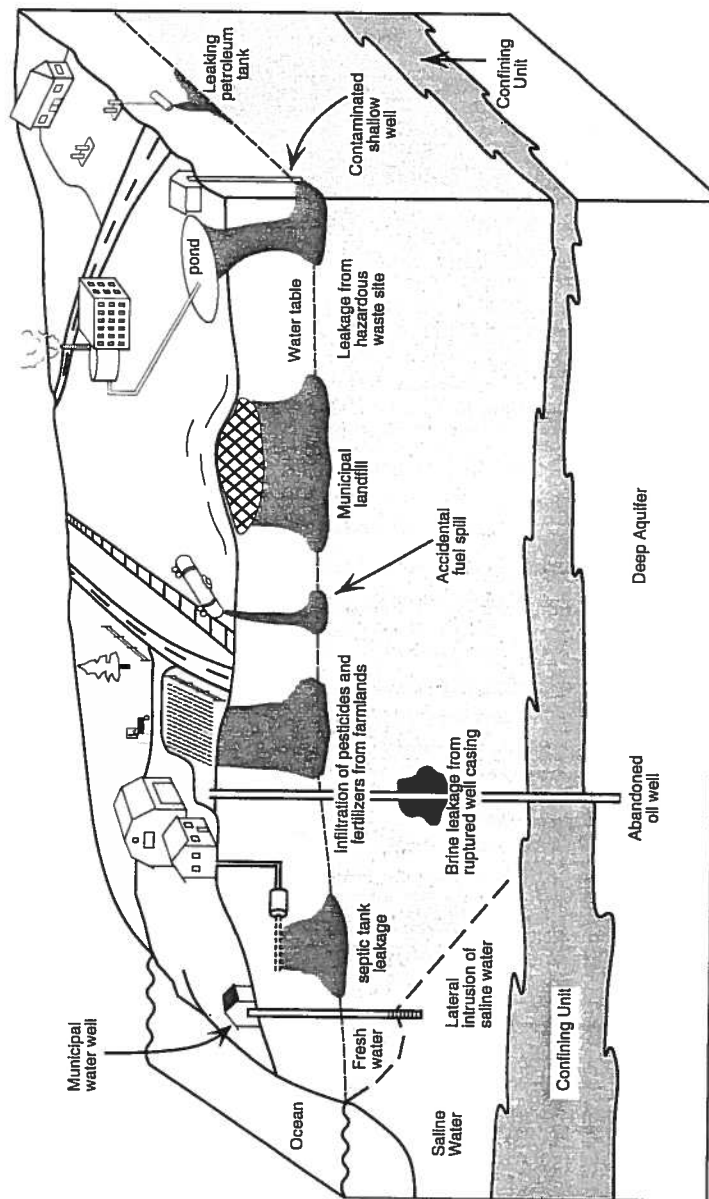

Figure 4.3 Mechanisms of ground water contamination.

TABLE 4.3 Typical Organic Compounds Found in Ground Water

Ground water contaminant	
Acetone	Methylene chloride
Benzene	Naphthalene
bis-(2-ethylhexyl)phthalate	Phenol
Chlorobenzene	Tetrachloroethene
Chloroethane	Toluene
Chloroform	1,2-trans-Dichloroethane
1,1-Dichloroethane	1,1,1-Trichloroethane
1,2-Dichloroethane	Trichloroethene
Di-n-butyl phthalate	Vinyl chloride
Ethyl benzene	Xylene

trichloroethylene (TCE) have been used for metal degreasing and for solvents, cleaners, dry cleaning fluids, paint removers, and printing inks.

Table 4.3 lists some of the more common organic compounds found in ground water along with their important properties. These compounds can generally be divided into categories: fuels and derivatives (BTEX), PAHs, alcohols, and ketones; halogenated aliphatics (trichloroethylene); halogenated aromatics (chlorobenzene); and polychlorinated biphenyls (PCBs). Chapter 7 presents more details on the properties and degradation pathways for fuels and chlorinated organics in ground water. The above compounds have been discharged to the environment in a number of ways over the years, beginning largely after World War II. While fuel contamination was recognized in the late 1980s as a major ground water problem associated with underground storage tanks, it has largely been replaced in the 1990s by chlorinated organic problems associated with industrial and military sites. Some of the largest underground contaminant plumes in the United States are located west of the Mississippi River, and involve chlorinated organics, which have migrated several miles in a number of cases.

The inorganic compounds occur in nature and may come from natural as well as man-made sources. Metals from mining, industry, metal finishing, wastewater, agriculture, and fossil fuel burning can present serious problems in ground water. Table 4.4 lists some of the more important trace metals occurring in ground water. Chromium may represent one of the most important metals because of its occurrence and mobility at a number of industrial sites that have impacted ground water.

TABLE 4.4 Examples of Trace Metals Occurring in Ground Water

Aluminum	Copper	Selenium
Antimony	Gold	Silver
Arsenic	Iron	Strontium
Barium	Lead	Thallium
Beryllium	Lithium	Tin
Boron	Manganese	Titanium
Cadmium	Mercury	Uranium
Chromium	Molybdenum	Vanadium
Cobalt	Nickel	Zinc

## 4.2 UNDERGROUND STORAGE TANKS

Underground tanks are ubiquitous in the environment. While most often associated with gasoline service stations, these tanks are also used by small and large industries, agriculture, governmental agencies, and private homes for storage of products. In general, fuels, oils, hazardous chemicals and solvents, and chemical waste products have been stored in below-ground tanks. The Office of Technology Assessment estimated in 1984 the number of storage tanks, both abandoned and in use, at approximately 2.5 million. A recent EPA survey (1990) found that 47 states indicated major ground water contamination from faulty underground tanks.

Many of the tanks were originally installed in the 1950s and 1960s and some are still in use today or have been abandoned or forgotten. Underground tanks can leak due to internal or external corrosion of the metal. Leaks can occur through holes in the tank or in associated piping and valves. In a recent survey of motor fuel storage tanks, the EPA found that 35% of the estimated 800,000 such tanks leaked. Steel tanks are being replaced by fiberglass tanks but faulty piping and subsequent leaks still occur. Figure 4.4 shows a typical double wall tank and leak detection system, a possible solution to the problems resulting from leaking tanks. Obviously, such systems are more expensive than older tanks and they have yet to be tested over time, but EPA and the individual states are involved in a major program to replace older tanks and to upgrade leak-detection systems.

The state of Texas alone was spending millions per year for investigation and cleanup of leaking underground storage tanks estimated at more than 5,000 in number. The remediation of underground storage tank plumes was a major focus of hydrogeologic assessments in the U.S. in the late 1980s and early 1990s. One of the most studied underground storage tank incidents in the U.S. was a fuel spill at the U.S. Coast Guard Station at Traverse City, Michigan. The spill of aviation gas and jet fuel resulted in a plume of contamination more

than 1 mile long and 500 ft wide, which polluted about 100 shallow municipal water wells.

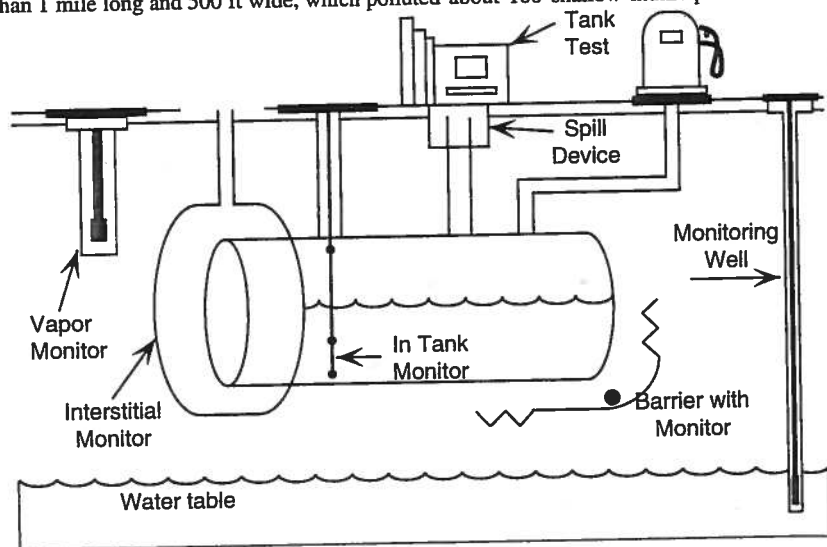

Figure 4.4 Typical double-walled tank and leak detection system.

The site has been the subject of extensive evaluation and remediation study, and more detail is provided in Chapters 8 and 13.

A different view of the true impact of underground storage tanks began to emerge in the mid 1990s when it became apparent that complete cleanups to EPA drinking water standards would not be affordable at many sites. In addition, two reports were written, one in California and one in Texas, which analyzed and reviewed in detail hundreds of leaking underground storage tank sites in an effort to draw general conclusions on rate and extent of ground water contamination. The California report (Lawrence Livermore National Laboratory, 1995) and the Texas report (Bureau of Economic Geology, 1997) both found that the median length of the ground water plume from typical UST sites was between 101 ft and 130 ft for California and between 190 ft and 260 ft for Texas. Thus, the size of the ground water impact at UST sites is much smaller than originally thought, due to processes of dilution and natural aerobic biodegradation of fuel components. Physical transport mechanisms associated with UST leaks and natural biodegradation issues are covered in more detail in Chapters 8 and 12.

### 4.3 LANDFILLS

Landfills today may be built with elaborate leak prevention systems, but most, particularly the older ones, are simply large holes in the ground filled with waste and covered with dirt. Originally designed to reduce the air pollution and unsightly trash that accompanied open dumping and burning, landfills became the disposal method for every conceivable type of waste. However, many were poorly designed and are leaking liquids or leachate, which have contaminated surrounding shallow ground water. According to EPA reports, there are approximately 2,395 open dumps and 24,000 to 36,000 closed or abandoned landfills in the U.S., and EPA estimates that 12,000 to 18,000 municipal landfills may contain hazardous wastes. In addition, there are an estimated 75,000 on-site industrial landfills. Materials placed in many of these landfills include garbage, trash, debris, sludge, incinerator ash, foundry waste and hazardous substances. Liquid hazardous wastes can no longer be legally disposed of in municipal landfills.

Many older landfills were located based on convenience rather than hydrogeologic study and consequently have been situated in environmentally sensitive marshlands, abandoned mines, gravel and sand pits, and sink holes. The disposal technology simply involved filling the hole with liquid and solid wastes, compacting with a bulldozer, and then covering with a layer of soil. As rainwater infiltrates through the top of a typical landfill, water levels increase inside the landfill creating a mounded condition, and leaching of inorganic and organic contaminants into the ground water can occur (Figure 4.5a). Thus, in many settings, the landfill acts like a surface impoundment that may be loaded with hazardous organic and inorganic materials. A number of older landfills have become famous study sites over the years and include the Borden landfill in Canada, the subject of extensive hydrogeologic and transport studies beginning in the early 1980s (Chapters 6 and 7). Other landfills and burial areas that were filled with hazardous waste and caused serious off-site problems include Love Canal in New York; Lone Pine landfill in New Jersey (Zheng et al., 1991); and the Vertac site in Arkansas.

Extensive siting, engineering, hydrologic, and hydrogeologic designs are required for the permitting of municipal and industrial landfills today. Modern landfills have leachate collection systems to control the migration of contaminants so they can be collected and transported off-site to a water treatment plant. A landfill must have a properly designed and constructed liner to minimize vertical migration, and a low-permeability cover to minimize off-site impacts. Many of the landfills built from the 1950s through the 1970s contained no liners or leachate collection systems, and have had serious leakage problems. Hazardous waste landfills are now regulated under the Resource Conservation and Recovery Act, and open dumps are no longer possible under Subtitle D of RCRA (see Chapter 14). Figure 4.5.b depicts the various design features of a modern hazardous waste landfill.

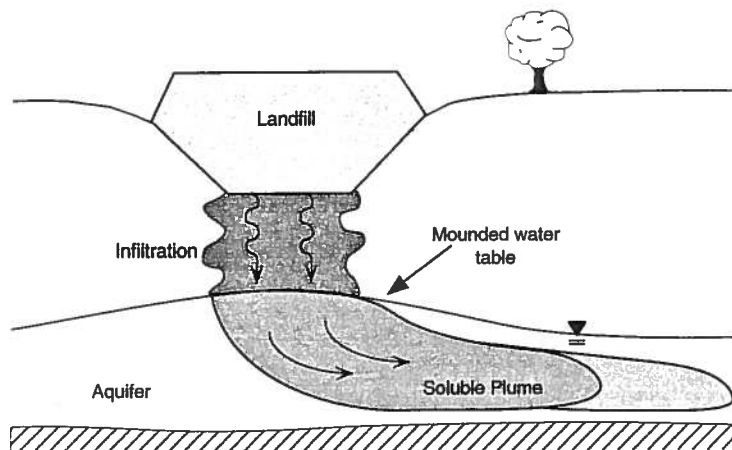

Figure 4.5a. Typical landfill with mounded water table.

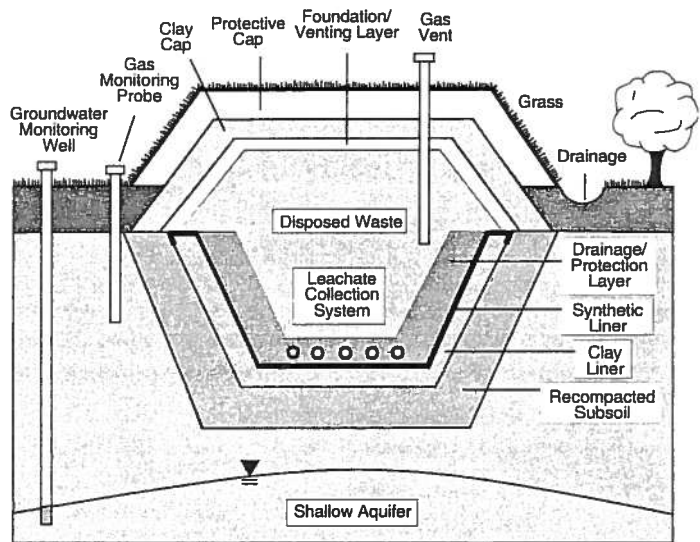

Figure 4.5b Typical modern hazardous waste landfill.

### 4.4 SURFACE IMPOUNDMENTS

Surface impoundments are often called pits, ponds, or lagoons. Ranging in size from a few square feet to several thousand acres, surface impoundments serve as disposal or temporary storage sites for hazardous and nonhazardous wastes. They are designed to accept purely liquid wastes, or mixed solids and liquids that separate in the impoundment. Chemical wastes in the impoundment are either treated and discharged to the environment, allowed to infiltrate the soil, or evaporate to the atmosphere. Prior to the passage of RCRA, liquid hazardous wastes were also discharged into pits that may have been lined or unlined with clay or other liner membranes.

Surface impoundments are commonly used by municipal wastewater and sewage treatment operations for settling of solids, biological oxidation, and chemical treatment. They are also used by animal feedlots and farms, and by many industries including oil and gas, mining, paper, and chemical operations. Water from surface impoundments may be discharged to streams and lakes. Many surface impoundments have been found to leak (Figure 4.6) and create large contaminated zones in the subsurface. The most famous case is the Rocky Mountain Arsenal near Denver, which discharged nerve gas and pesticides into unlined evaporation ponds from 1942 until 1956. Contamination of nearby wells was detected in the early 1950s when irrigated crops died and ground water contamination extended over an eight-mile region. The ground water under the Rocky Mountain Arsenal has been found more recently to contain many synthetic organic contaminants associated with the manufacture of nerve gas and pesticides (Konikow and Thompson, 1984). It is estimated that the cleanup of contaminated soil and ground water at the arsenal will ultimately cost more than \$1 billion.

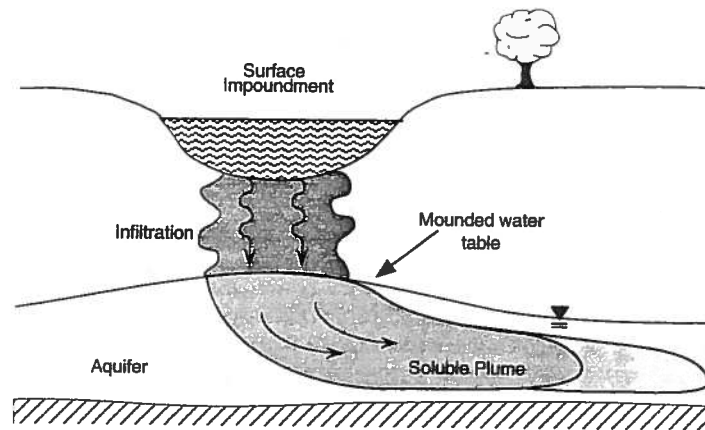

Figure 4.6 Surface impoundment leak.



In 1982 EPA identified over 180,000 waste impoundments including 37,000 municipal, 19,400 agricultural, 27,912 industrial, 25,000 mining, and 65,688 brine pits for oil and gas (EPA 1982). Of the industrial sites evaluated, 95% were within one mile of drinking water wells, 70% were unlined and 50% were on top of aquifers. Thus, impoundments represent a major and continuing source for migration of organic and inorganic chemicals to ground water by often causing a mounded condition in the subsurface. Most industrial sites where contamination problems have occurred have one or more impoundments located on site.

Discharge of water with chlorinated solvents into impoundments at Plant 44 near Tucson, Arizona contributed to one of the largest chlorinated ground water plumes in the U.S. The contaminants impacted water supply wells and created a ground water plume over six miles long in the downgradient direction (Section 13.9.1).

#### 4.5 WASTE DISPOSAL INJECTION WELLS

Injection wells are used to discharge liquid hazardous waste, brine, agricultural and urban runoff, municipal sewage, aquifer recharge water, and fluids used in solution mining and oil recovery into the subsurface. Every year in the United States millions of tons of toxic, hazardous, radioactive, and other liquid wastes are dumped directly into the subsurface through thousands of waste disposal wells. This practice, most commonly utilized by the chemical, petroleum, metals, minerals, aerospace, and wood-preserving industries, has contaminated ground water in over 20 states.

Injection wells can cause ground water contamination if the fluid enters a drinking water aquifer due to poor well design, faulty construction, or inadequate understanding of the geology. Wastewater can migrate vertically upward into a drinking water aquifer through cracks, fault zones, or abandoned well casings. Figure 4.7 shows a typical deep well injection of liquid waste. Normally, such wells are designed to have pressure gages and monitoring wells to detect any leak or fracture problems with the injection. Injection wells are now regulated under the Underground Injection Control Program of the Safe Drinking Water Act. The RCRA amendments of 1984 prohibit the underground injection of certain hazardous wastes.

The injection wells that pose the greatest threat to ground water include agricultural wells, septic system wells, brine injection wells, and deep wells for hazardous waste. An additional concern is that wastes that have been disposed of earlier may migrate into drinking water aquifers due to fractures and faults in abandoned casings (Figure 4.8). The injection fluid is under pressure and creates a zone of influence that extends beyond the well casing (Chapter 3). If abandoned oil wells or deteriorating well casings are in the immediate area, they can possibly provide vertical conduits to water supply aquifers that reside above.

A serious problem that exists in oil-producing states is the disposal of brine waters via surface pits or injection wells. Ten gallons of salt water are produced and brought to the surface for every gallon of oil pumped out of the ground. The brine waters are often rein-

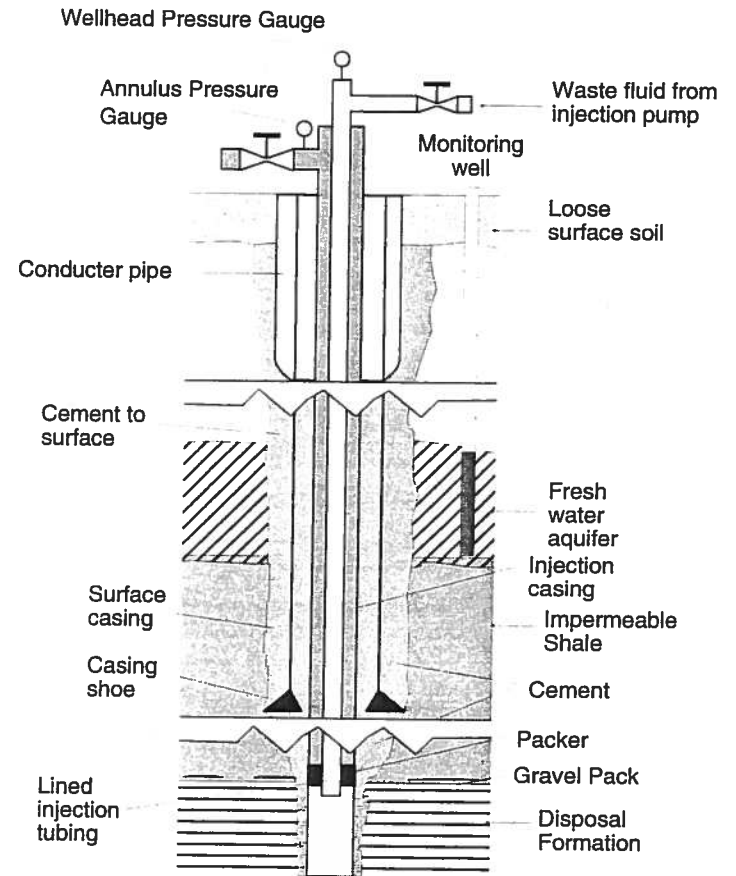

Figure 4.7 Deep well injection of liquid wastes.

jected into wells, and in some cases, have contaminated nearby aquifer systems or surface streams. The problem is particularly acute where aquifers can transport the salt water over large distances. Many of these problem sites were developed decades ago (1940s and 1950s) before modern technology for proper brine control and disposal was introduced.



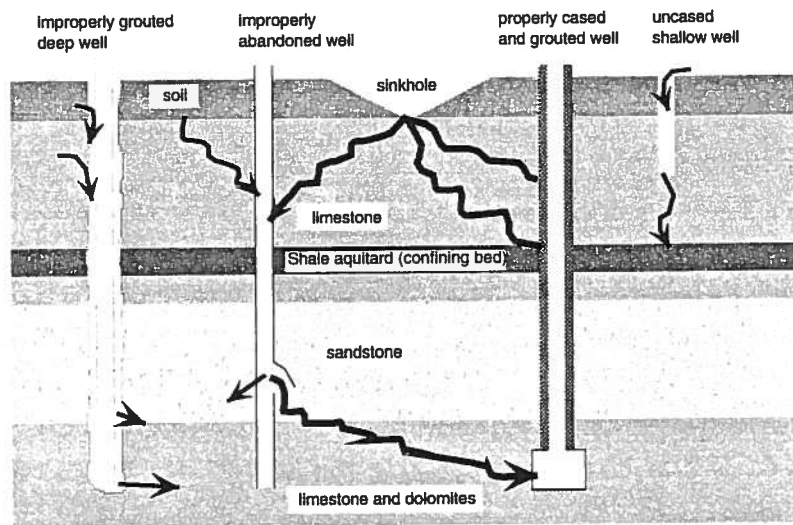

Figure 4.8 Aquifer contamination through improperly constructed or abandoned wells.

## 4.6 SEPTIC SYSTEMS

Approximately 22 million septic systems are operating in the United States today, and about one-half million new systems are installed every year. These systems serve nearly thirty percent of the nation's population.

Septic systems generally are composed of a septic tank and a drain field into which effluent flows from the tank (Figure 4.9). Within the tank, physical processes separate the inflow into sludge (which accumulates on the bottom of the tank), wastewater, and scum (which forms on top of the wastewater). Once a tank reaches a certain percentage of its capacity, the sludge and scum, called septage, must be pumped out, so the tank will continue to function properly.

Serious system failures are usually quite evident because wastes will surface and flood the drainage field (not only causing an odor, but also exposing people to pathogenic bacteria and viruses). Unfortunately, we cannot see or smell contaminants from underground systems that leach into aquifers. Years may pass before contamination emanating from poorly designed systems is detected. Septic systems discharge a variety of organic and inorganic compounds including BOD, COD, TSS, fecal coliform bacteria, nitrates and nitrites, ammonia

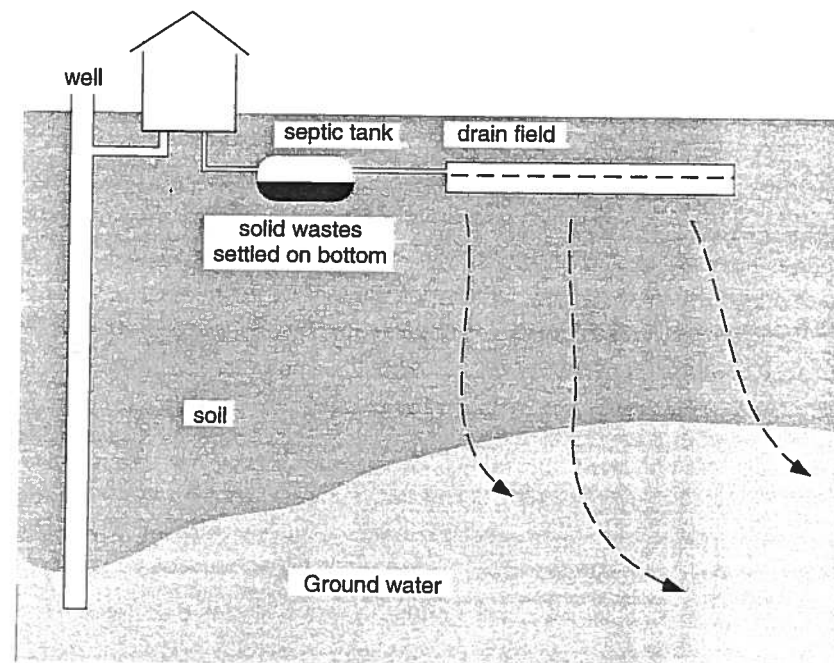

Figure 4.9 A typical septic system.

and phosphorus. Synthetic organic chemicals such as TCE, benzene, and methylene chloride may also be discharged to the subsurface.

Commercial and industrial septic systems present unique and potentially more severe problems to ground water contamination than do domestic systems due to the hazardous nature of the wastes disposed of in these systems. Chemicals including nitrates, heavy metals such as lead, copper, and zinc, and certain synthetic organic chemicals, such as benzene, PCE, TCE, and chloroform are dumped into such systems. The EPA has identified several commercially used septic systems as sources of chemical contamination at sites around the nation designed for cleanup under the federal Superfund law.

In addition, many small businesses including dry cleaners, hardware stores, restaurants, service stations, and laboratories contaminate ground water through commercial septic systems. A number of dry cleaner sites in Texas and California were recently identified as major sources for PCE contamination in the subsurface. At many of the sites, the sources include leaks at the surface, but also leaks into the sanitary sewer system, which then leaked NAPLs into shallow ground water. There is evidence that the PCE then biodegraded into TCE and

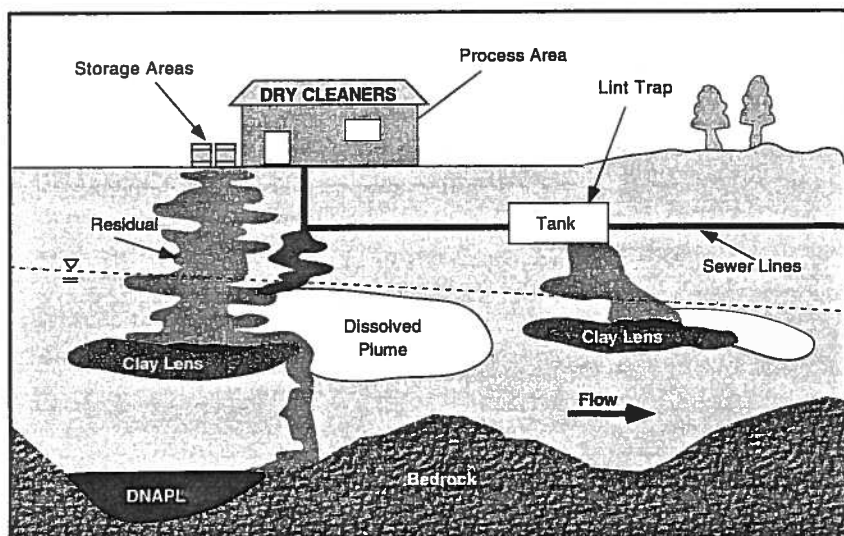

Figure 4.10 Routes of migration that can occur from leaks and faulty equipment at a typical dry cleaner operation.

DCE contaminants in creating off-site plumes. Figure 4.10 depicts the routes of migration that can occur from leaks and faulty equipment at a typical dry cleaner operation.

## 4.7 AGRICULTURAL WASTES

Pesticides were first identified in ground water less than ten years ago, but now over 35 states report ground water contaminated by pesticides. Recent limited ground water monitoring efforts are only beginning to tell the story of decades of often indiscriminate pesticide use. Pesticides have been widely used for many purposes such as weed control, insecticides, fungicides, and defoliant. There are 50,000 different pesticide products in the U.S. composed of 600 active ingredients. They are used on agricultural fields, on golf courses, lawns and gardens, roadsides, parks, home foundations, and in wood products. They can contaminate ground water through migration through the soil to the water table. Many in use today are biodegradable to some extent. More than 65% of pesticides are applied by aerial spraying and pose a special problem. (Rachel Carson's *Silent Spring*, published in 1962, is a classic book that exposed the serious problem of pesticide use in the U.S.)

Fertilizers from agriculture can also provide a major source of elevated nutrient levels to the subsurface. Nitrogen, potassium, and phosphorous are the three basic fertilizers, but

nitrogen represents over half of the total used and is the most likely to leach to ground water, while phosphorous is not very mobile and does not pose a significant threat to ground water. The use of nitrogen on U.S. agricultural lands increased 38% from 1975 to 1981, bringing the total to over 10 million metric tons. In a recent USGS survey, 20% of the sample had a nitrate concentration of over 3 mg/L, and 6% had a nitrate concentration exceeding EPA's 10mg/L limit for drinking water. Nitrates represent the most frequently reported contaminant considered a major threat to ground water quality according to the *National Water Quality Inventory 1988*, but nitrates are also generated in septic tank wastes and in urban runoff.

The production of millions of tons of manure by agricultural sources annually contaminates underlying aquifers with nitrogen, bacteria, viruses, hormones, and salts. Although ground water can be contaminated by relatively small livestock operations if they are located above porous soils, the most obvious threat stems from animal feedlots, where dense livestock populations are confined to small areas. Facilities that treat or dispose of animal wastes likewise pose a threat to local ground water.

Modern irrigation practices can lead to salt contamination and high levels of TDS in underlying aquifers. Irrigation water contains small quantities of salt which, because they are not transpired by crops or evaporated from soil, build up within the soil and eventually leach into ground water. Irrigation return flows that eventually reach rivers and streams may also contribute to ground water contamination, especially in arid areas. In arid and semi-arid areas of the country, excess irrigation water is applied to rid the root zone of potentially crop-devastating salt buildup. Though it may maintain crop productivity, this practice degrades underlying ground water supplies, and is a major problem in the western U.S.

Agricultural sources of contamination to ground water have generally been ignored under hazardous waste legislation, but as urban sprawl continues to expand into former agricultural areas, pesticide, salt, and nitrate issues may again become important in the future.

## 4.8 LAND APPLICATION AND MINING

Land application is a treatment and disposal method also called land treatment and land farming. The practice involves spreading waste sludges and wastewater generated by public treatment works, industrial operations such as paper, pulp and textile mills, tanneries and canneries, livestock farms, and oil and gas exploration and extraction operations. Wastewater is applied primarily by a spray irrigation system, while sludge from wastewater plants is generally applied to soil as a fertilizer. Oily wastes from refining operations have been land farmed in soil to be broken down by soil microbes. If properly designed and operated, land application recycles nutrients and waters to the soil and aquifer.

Over 20 states reported land application as a major threat to ground water. Contamination occurs when heavy metals, toxic chemicals, nitrogen, and pathogens leach to underlying aquifers. This occurs if the sludge or waste water has not received adequate pretreatment or if the depth to ground water has not been properly considered. In some cases the hazardous materials do not degrade in the subsurface. For example, 40% of California's hazardous wastes

were treated by land farming practices. The land application of hazardous wastes has received major attention from EPA in recent years and is no longer an approved technology in most aquifer settings.

The construction techniques, products, and by-products of mining operations have been serious threats to the quality and quantity of nearby aquifers for decades. Surface and underground mining may disrupt natural ground water flow patterns and create the potential for acid mine drainage to seep from the mine. Millions of acres of U.S. land have been mined for coal, copper, uranium, and other minerals. Mine tailings and associated pits also create serious problems as water comes in contact with metals and other wastes. Inactive and abandoned mines as well as active mines can be steady and serious sources of contamination; there are an estimated 67,000 inactive or abandoned mines in the United States.

## 4.9 RADIOACTIVE CONTAMINANTS

The massive production of radioactive isotopes by weapons and nuclear reactors since World War II has been accompanied by increasing concern about environmental and health effects. The top secret "Manhattan Project", which resulted in the first atomic bomb, created a huge industry for the research, manufacture, and testing of nuclear weapons that, of course, continued into the late 1980s. The legacy of the Cold War has been a nuclear weapons complex that spreads from one coast to the other, and includes some of the most contaminated sites on the planet. At its peak, the complex consisted of 16 major facilities, including vast reservations of land in Nevada, Idaho, Washington, and South Carolina. Figure 4.11 depicts the various sites around the U.S., and indicates some of the processes carried out at the sites, now owned and controlled by the Department of Energy, originally set up in 1977.

Radionuclides are unstable isotopes of elements, including fission products of heavy nuclei such as uranium and plutonium and naturally occurring isotopes such as carbon-14. Large quantities of radioactive wastes have been produced by the nuclear weapons industry in the U.S. The ultimate disposal of radioactive wastes has caused major controversy regarding the widespread use of nuclear power.

Radionuclides emit ionizing radiation in the form of alpha particles, beta particles, and gamma rays. Gamma rays are the most damaging and are a form of electromagnetic radiation, like X-rays, though more energetic. The decay of a specific radionuclide follows a first order decay law, which can be expressed  $C = C_0 e^{-\lambda t}$ , where  $C$  is the activity at time  $t$ ,  $C_0$  is the initial activity at time 0, and  $\lambda$ , the decay coefficient, is related to the half-life by  $t_{1/2} = 0.693/\lambda$ . The half-life is defined as the time during which 50% of a given number of radioactive atoms will decay. First-order decay is described in more detail in Chapter 6. Table 4.5 summarizes the major natural and artificial radionuclides typically encountered in water and their associated half-lives.



Figure 4.11 U.S. map of various nuclear sites.

TABLE 4.5 Radionuclides in Water

Radionuclide	Half-life
Naturally occurring and from cosmic reactions	
Carbon 14	5730 years
Silicon 32	~300 years
Potassium 40	~1.4 X 10 <sup>10</sup> years
Naturally occurring from 238U series	
Radium 226	1620 years
Lead 210	21 years
Thorium 230	75,200 years
Thorium 234	24 days
From reactor and weapons fission	
Strontium 90	28 years
Iodine 131	8 days
Cesium 137	30 years
Barium 140	13 days
Zirconium 95	65 days
Cerium 141	33 days
Strontium 89	51 days
Ruthenium 103	40 days
Krypton 85	10.3 years
Cobalt 60	5.25 years
Manganese 54	310 days
Iron 55	2.7 years
Plutonium 239	24,300 years

The nuclear industry is currently the main generator of radioactive contaminants. Potential sources occur in uranium mining and milling, fuel fabrication, power plant operation, fuel reprocessing and waste disposal. The disposal of civilian radioactive wastes and uranium mill tailings is licensed under the Nuclear Regulatory Commission. High level radioactive wastes from nuclear power plants are currently in temporary storage but will eventually go into an underground repository such as the one planned for Yucca Mountain, Nevada. Low level wastes and medical wastes are currently buried in shallow landfills.

Unless radioactive wastes are properly handled in well-designed sites, the potential for migration to ground water exists. The most serious problems with radioactive contamination exist at a number of facilities including Oak Ridge, Tennessee; the Hanford Site in Washington State; the Savannah River Site in Georgia; and the Idaho National Engineering Laboratory. The Hanford Site contains a ground water plume of tritium that is more than 12 miles long and 8 miles wide and flows into the Columbia River. Figure 4.12 shows barrels of transuranic waste that contain traces of plutonium, located at the East Burial Grounds at the Savannah River Site. More than 300,000 barrels of these wastes are stored around the country. These and other associated nuclear weapons facilities are the subject of massive environmental studies and remediation efforts for both ground water and soils or building contamination.



Figure 4.12 Barrels of transuranic waste. Source: DOE, 1995.

The health hazards associated with radiation leaks are well known but the risks are difficult to assess at low levels of exposure. Even though the Department of Energy is spending large sums of money to address environmental problems, the true impact of radioactive waste disposal may not be known for decades. An excellent review of the environmental legacy of the nuclear weapons industry can be found in a 1995 DOE report, "Closing the Circle on the Splitting of the Atom."

#### 4.10 MILITARY SOURCES OF CONTAMINATION

According to the Citizen's Clearinghouse for Hazardous Waste, the U.S. military branches may be the largest generators of hazardous waste in the country, producing over 1 billion pounds per year, more than that produced by the top five civilian chemical companies combined. Numerous spills, leaks, and landfills have been discovered on military bases throughout the country and are the subject of intense investigation and remediation efforts. The U.S. Air Force alone estimates more than 4,300 waste sites and spills on more than 100 of their bases. Some of these military sites are currently on the EPA national priority list as Superfund sites. Many of the sites have contaminant plumes associated with all of the contaminants already discussed, including fuels, chlorinated solvents, trace metals, and other organics.

One of these air force sites is Plant 44 in Tucson, Arizona, where missiles and guidance systems were manufactured, and planes were repaired and painted. The operations at the site created a TCE and chromium plume of contamination that extends six miles in length and half a mile in width, and flows through the city of Tucson. Many of the water supply wells for the city have been contaminated with TCE and associated daughter products, and have been taken out of service over the years. The site has been the subject of major site investigations, remediation, and evaluation involving the air force, EPA, and the Tucson Airport authority. The Hughes Plant 44 site is currently being remediated with a one of the largest pump and treat systems in the U.S., designed to withdraw and treat up to 5000 gal/min of water from the aquifer located over 100 ft below the surface. This site is described in more detail in Chapter 10.

Hill Air Force Base (AFB) in Utah has several areas of environmental damage, including Operable Unit 1 (OU 1), a former chemical disposal pit/fire training area. This base is one of the premier repair facilities for the U.S. Air Force, and over the years, massive dumping of chlorinated solvents and fuels has occurred at several locations on base. One area on the base had a significant BTEX plume, which impacted an area of housing in the downgradient direction. The area of OU 2 was severely contaminated with DNAPL near the base boundary and was the subject of extensive testing of surfactant remediation techniques in 1996-97 (Hirasaki et al., 1998). Finally, a major soil vapor extraction test was demonstrated at the base, and is described in more detail in Chapter 9 (El Beshry et al., 1998). The extensive contamination and the security of a military installation at Hill AFB provided an ideal site where many experiments involving advanced remediation methods could be tested.

In the summer of 1996, nine individual cells were constructed within a contaminated NAPL zone of the shallow aquifer at the site (Bedient et al., 1999). The area at OU 1 is contaminated with a light nonaqueous phase mixture of chlorinated solvents and fuel hydrocarbons, which are present in residual and free phase across the site. Nine enhanced aquifer remediation technologies were demonstrated in side-by-side tests at the Hill AFB site. The demonstrations were performed inside 3 m x 5 m cells isolated from the surrounding shallow aquifer by steel sheet piling. The technologies demonstrated were designed to manipulate the solubility, mobility, and volatility of the contaminants in order to enhance the aquifer remediation over a standard "Pump-and-Treat" system. Over 80,000 samples of water and soil were collected as part of tracer tests, soil flushing demonstrations, and routine characterization efforts at OU 1.

Hill AFB's OU 1 site was chosen because all nine technologies could be demonstrated side-by-side, within a similar hydrogeology with similar contamination levels. To facilitate comparisons among the nine technologies being demonstrated, the cell instrumentation, characterization, and basic study methodology were standardized prior to the beginning of field work. Each of the studies was conducted in a test cell designed to separate the test area from the surrounding environment. The demonstrated technologies facilitated contaminant removal through dissolution, emulsification, or mobilization in ground water or through volatilization and enhanced bioremediation when air delivery systems were used. In some cases, this was the first time that remediation approach had been demonstrated in the field. More details and results from surfactant (Sabatini et al., 1999) and cosolvent (Rao et al., 1997) tests are described in the advanced remediation section of Chapter 13.

## 4.11 CLASSIFICATION OF ORGANIC COMPOUNDS

In the past 20 years, organic compounds in ground water have come to be recognized as one of the major threats to human health. This section will introduce some of the major classes and some of the most important compounds found in ground water. More detailed coverage on organic compounds in ground water can be found in Pankow and Cherry (1996), Manahan (1991), Sawyer et al. (1994), Schwarzenbach et al. (1993), and Fetter (1999).

Organic chemistry deals with the chemistry of carbon compounds; carbon is a unique element in that it forms four covalent bonds and is capable of bonding to other carbon atoms, with single, double, or triple bonds. It is this characteristic of carbon that gives rise to the possibility of great diversity in the physical and chemical properties of organic compounds. The simplest organic compounds are hydrocarbons consisting of carbon and hydrogen alone. The traditional approach to classifying organic compounds involves defining functional groups, which include a simple combination of two or more of the following atoms: C, H, O, S, N, P. Domenico and Schwartz (1998) present a condensed scheme of classification consisting of 16 major classes (Table 4.6) and is a useful approach for organizing organic contaminants in ground water. Elements such as O, N, S, P, H, and Cl can bond

TABLE 4.6 Classification of Organic Compounds

### 1. Miscellaneous Nonvolatile Compounds

#### 2. Halogenated Hydrocarbons

##### Alliphatic

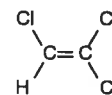

Trichloroethylene

##### Aromatic

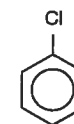

Chlorobenzene

### 3. Amino Acids

#### Basic Structure

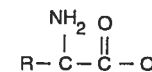

#### Aspartic acid

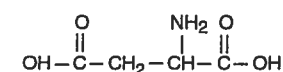

### 4. Phosphorous Compounds

#### Basic Structure

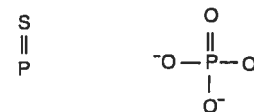

#### Malathion

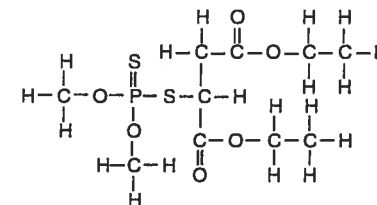

### 5. Organometallic Compounds

#### Tetraethyllead

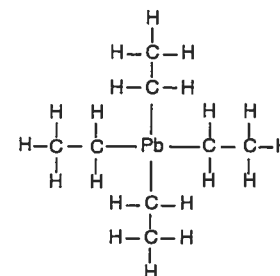

### 6. Carboxylic Acid

#### Basic Structure

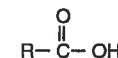

#### Acetic acid

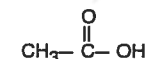
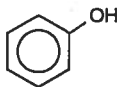

TABLE 4.6 Classification of Organic Compounds (continued)

## 7. Phenols

Basic Structure



Cresol

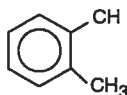

## 8. Amines

Basic Structure

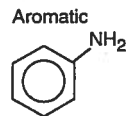

Aliphatic

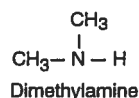

## 9. Ketones

Basic Structure

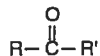

Acetone

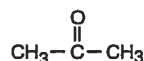

## 10. Aldehydes

Basic Structure

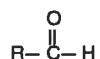

Formaldehyde



## 11. Alcohols

Basic Structure



Methanol



## 12. Esters

Basic Structure

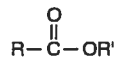

Vinyl acetate

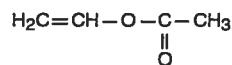

## 13. Ethers

Basic Structure



1,4-Dioxane



## 14. Polynuclear Aromatic Hydrocarbons

Phenanthrene

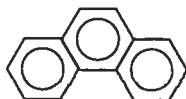

TABLE 4.6 Classification of Organic Compounds (continued)

## 15. Aromatic Hydrocarbons

Basic Structure



Toluene

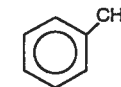

## 16. Alkane, Alkene, and Alkyne Hydrocarbons

Ethane

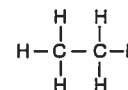

Ethene

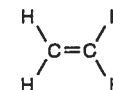

Ethyne



R = aliphatic backbone

with carbon at any of four locations. Other groups such as OH and CH<sub>3</sub> can also bond with carbon to form many other compounds of interest. Hydrocarbons can be divided into aromatics, which contain a benzene ring, and aliphatics, which are compounds of C and H that are linked to a straight or branched carbon chain.

## 4.11.1 Aliphatic Hydrocarbons

The aliphatic hydrocarbons with more than one carbon atom can be classified as alkanes (single bonds), alkenes (double bonds) or alkynes (triple bonds). Straight chain alkanes include methane (CH<sub>4</sub>), ethane (H<sub>3</sub>CCH<sub>3</sub>), propane (H<sub>3</sub>CCH<sub>2</sub>CH<sub>3</sub>), butane, pentane, and hexane. These compounds are known as saturated hydrocarbons or paraffins. Alkanes can also have branched chains creating isomers with the same formula but with different properties. They conform to the general formula C<sub>n</sub>H<sub>2n+2</sub>, where *n* is the number of carbon atoms. Cycloalkanes are characterized by a ring structure that contains single C-C bonds such as cyclopropane and cyclohexane.

## 4.11.2 Aromatic Hydrocarbons

Aromatic hydrocarbons are compounds with a molecular structure based on that of the benzene ring, C<sub>6</sub>H<sub>6</sub>. These compounds are a major constituent of petroleum and related products. Typical benzene-related compounds are shown in Figure 4.13 where the benzene molecule consists of six carbon and six hydrogen atoms in a cyclical form. The ring in the center represents a delocalized cloud of electrons. The carbon atoms in benzene are also capable of bonding to functional groups, and isomerism is possible. Nomenclature includes numbering the ring from 1 to 6 starting at the top of the ring. More than one functional group may



Name	Structure	Molecular Weight	Solubility in Water	Soil-Water Partition Coefficient
Benzene		78.11	1780 mg/L	97
Toluene		92.1	500 mg/L	242
Xylene, ortho		106.17	170 mg/L	363
Xylene, meta		106.17	173 mg/L	182
Xylene, para		106.17	200 mg/L	331
Ethyl benzene		106.17	150 mg/L	622

Figure 4.13 Benzene related compounds.

result in *ortho*-, *meta*-, or *para*- isomers, as in the case of xylene, which contains two methyl groups (Figure 4.10).

When several of the benzene rings are joined together, polycyclic aromatic hydrocarbons (PAH), such as naphthalene (2 benzene rings), phenanthrene (3 benzene rings), and benzo-a-pyrene (5 benzene rings) are formed. Figure 4.14 shows several of the important PAH's in ground water. These compounds are found in petroleum products, asphalt, coal tar, creosote and result from the incomplete combustion of fossil fuels. If the benzene ring is joined to another group, it may be referred to as a functional group, phenyl, and in combination with chlorine these compounds are called polychlorinated biphenyls (PCBs). They are extremely resistant to chemical, thermal, or biological degradation and tend to persist in the

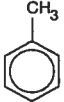
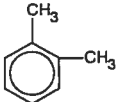
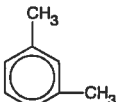

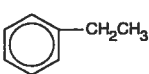
Name	Structure	Molecular Weight	Solubility in Water	Soil-Water Partition Coefficient
Naphthalene		128.16	31.7 mg/L	1300
Acenaphthene		154.21	7.4 mg/L	2580
Acenaphthylene		152.2	3.93 mg/L	3814
Fluorene		166.2	1.98 mg/L	5835
Fluoranthene		202	0.275 mg/L	19000
Phenanthrene		178.23	1.29 mg/L	23000
Anthracene		178.23	0.073 mg/L	26000

Figure 4.14 Structure and properties of some polycyclic aromatic hydrocarbons (PAHs).

environment. Because of human health and environmental effects, the manufacture of PCBs was banned in the U.S. in 1977. PCBs associated with the energy industry comprise some of the most serious contaminants to soils and ground water.

Alkenes are unsaturated hydrocarbons and have a carbon-carbon double bond with the general formula  $C_nH_{2n}$ , and include such compounds as ethene and propene, also called ethyl-

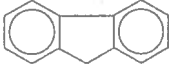
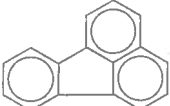
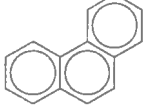
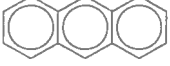

ene and propylene. Alkenes are referred to as olefins or the ethylene series. If functional groups are present, their position is indicated by the carbon atom to which they are bonded, and structural isomers can exist. Many of the chlorinated solvents (such as trichloroethylene) are of great concern as ground water contaminants at industrial sites. The acetylene series (alkynes) have triple bonds between two adjacent carbon atoms.

Phenols are characterized by a benzene ring with one attached hydroxyl group. They originate in ground water mostly as contaminants from industrial wastes or biocides. Phenol is a common ground water contaminant due to its many industrial uses and can also occur naturally with decomposing organic matter. Cresols have a methyl group and OH attached to the benzene ring and are used for the coal tar refining and for wood preservation. For example, Lysol is a mixture of cresols and is sold as a household disinfectant. Chlorophenols are used as wood and leather preservatives and as antimildew agents. Phenol, in general, has acute toxic effects on bacteria and has been used as a disinfectant and germicide. Pentachlorophenol has been found at a number of creosote wood preserving sites and represents a highly toxic and nonbiodegradable compound.

Benzene is a carcinogen and inhaled benzene is readily absorbed by blood and is strongly taken up by fatty tissues. Benzene can be converted to phenol by an oxidation reaction in the liver that is responsible for the unique toxicity of benzene, which involves damage to bone marrow, and is known to cause leukemia. Benzene is also a skin irritant and can affect the central nervous system. Toluene is classified as moderately toxic and is much less toxic than benzene because it is readily excreted from the body. (Manahan, 1991).

#### 4.11.3 Alcohols

Alcohols have one or more OH groups, are miscible with water, and have the potential for significant mobility; however, they are readily biodegraded. Alcohols are considered the primary oxidation product of hydrocarbons. At many industrial sites, alcohols are discharged into ground water and can act as solvents for other organics. Common alcohols include methanol ( $\text{CH}_3\text{OH}$ ), ethanol ( $\text{C}_2\text{H}_5\text{OH}$ ), 1-propanol, and isopropyl ( $\text{C}_3\text{H}_7\text{OH}$ ). Selected alcohols are being used experimentally as cosolvents to help solubilize NAPLs from the subsurface. Aldehydes are the oxidation products of primary alcohols, and ketones are the oxidation products of secondary alcohols.

#### 4.11.4 Halogenated Hydrocarbons

Halogenated hydrocarbons are one of the largest and most important groups of contaminants found in ground water. This group consists of both aliphatic and aromatic subclasses and is characterized by the presence of one or more halogen atoms (Cl, Br, F). Included in the aliphatic group are solvents such as methylene chloride, chloroform, tetrachloroethylene (PCE), trichloroethylene (TCE), 1,2 dichloroethylene (1,2 DCE), and vinyl chloride. Many of the halogenated ethenes have been found in large quantities in ground water, associated with industrial sites where solvents, cleansers, and degreasers were used. Many of these compounds

in the halogenated group are biodegradation products from other chlorinated compounds in the production of plastics (Chapter 7 and Figure 4.15).

The aromatic group of chlorinated pesticides includes DDD, DDE, DDT, and 2,4-D and 2,4,5-T compounds. The latter two are herbicides and were used as defoliants in Vietnam. Dioxin (2,3,7,8-dioxin), an extremely toxic organic to humans, is a byproduct contaminant of 2,4,5-T production, and has been found at sites where chlorinated organics were burned. Organic phosphorus pesticides include malathion, which is toxic to insects but not to mammals.

The specific toxicity of halogenated hydrocarbons varies with the compound but most affect the central nervous system. Carbon tetrachloride, for example, is a systemic poison that affects the nervous system, the intestinal tract, liver and kidneys. Over the years the FDA compiled a grim record of toxic effects and eventually banned its household use in 1970. Vinyl chloride has been used widely in the production of PVC materials and exposure can affect the central nervous system, respiratory system, liver, blood and lymph systems. Most notably, vinyl chloride is a carcinogen. The dichlorobenzenes are irritants that affect the respiratory system, liver, skin and eyes, through inhalation or contact. Polychlorinated biphenyls (PCBs) have been widely used in the electrical industry as hydraulic fluids in transformers. They represent extremely persistent environmental pollutants with a strong tendency to undergo bioaccumulation in lipid tissue (Manahan, 1991).

The use and disposal of chlorinated solvents by industries involved in electronics manufacturing, metal degreasing, engine repair, paint stripping, and plastics have created a number of serious chlorinated organics plumes, especially in the western U.S. The Hughes Plant 44 Superfund site in Arizona is an example of a site seriously contaminated with halogenated hydrocarbons (see Chapter 10).

#### 4.11.5 Other Organic Compounds

Table 4.6 indicates other classes of organic compounds. Esters are the result of the combination of an alcohol with a carboxylic acid. Esters are used as flavorings, perfumes, solvents and paints. One important class of esters is the phthalates, which are used to improve the flexibility of various plastics. Ethers have an oxygen atom strongly bonded between two carbon atoms and thus have relatively low toxicities.

Organic compounds that contain nitrogen are common in industry and are used for the manufacturing of explosives. Aniline and diphenylamine are aromatic compounds that contain nitrogen in aromatic rings. Trinitrotoluene (2,4,6-TNT) is the main ingredient of military explosives, and has been reported as a soil contaminant in areas where munitions are manufactured.

Name	Structure	Uses and Other Sources
Trichloromethane (chloroform)	$\begin{array}{c} \text{Cl} \\   \\ \text{Cl}-\text{C}-\text{Cl} \\   \\ \text{H} \end{array}$	Liquid used in manufacture of anesthetics, pharmaceuticals, fluorocarbon refrigerants and plastics. Used as solvent and insecticide. Formed from methane when chlorinating drinking water.
Vinyl chloride (chloroethene)	$\begin{array}{c} \text{H} \quad \text{H} \\ \diagdown \quad / \\ \text{C}=\text{C} \\ / \quad \diagdown \\ \text{H} \quad \text{Cl} \end{array}$	Gas used in the manufacture of polyvinyl chloride. End product of microbial degradation of chlorinated ethenes.
Chloroethane	$\begin{array}{c} \text{H} \quad \text{H} \\   \quad   \\ \text{H}-\text{C}-\text{C}-\text{Cl} \\   \quad   \\ \text{H} \quad \text{H} \end{array}$	Liquid used to manufacture tetraethyl lead. Degradation product of chlorinated ethanes.
1,2-Dichloroethane	$\begin{array}{c} \text{H} \quad \text{H} \\   \quad   \\ \text{Cl}-\text{C}-\text{C}-\text{Cl} \\   \quad   \\ \text{H} \quad \text{H} \end{array}$	Liquid used to manufacture vinyl chloride. Degradation product of trichloroethane.
Trichloroethene (Trichloroethylene)	$\begin{array}{c} \text{Cl} \quad \text{Cl} \\ \diagdown \quad / \\ \text{C}=\text{C} \\ / \quad \diagdown \\ \text{Cl} \quad \text{H} \end{array}$	Solvent used in dry cleaning and metal degreasing. Organic synthesis. Degradation product of tetrachloroethene.
Tetrachloroethene (perchloroethene) (perchloroethylene)	$\begin{array}{c} \text{Cl} \quad \text{Cl} \\ \diagdown \quad / \\ \text{C}=\text{C} \\ / \quad \diagdown \\ \text{Cl} \quad \text{Cl} \end{array}$	Solvent used in dry cleaning and metal degreasing. Used to remove soot from industrial boilers. Used in manufacture of paint removers and printing inks.
1,2-Dibromo-3-chloropropane (DBCP)	$\begin{array}{c} \text{Br} \quad \text{Br} \quad \text{Cl} \\   \quad   \quad   \\ \text{H}-\text{C}-\text{C}-\text{C}-\text{H} \\   \quad   \quad   \\ \text{H} \quad \text{H} \quad \text{H} \end{array}$	Soil fumigant to kill nematodes. Intermediate in organic synthesis.
o-Dichlorobenzene (1,2-dichlorobenzene)		Chemical intermediate. Solvent. Fumigant and insecticide. Used for industrial odor control. Found in sewage form odor control chemicals used in toilets.

Figure 4.15 Chlorinated organics found in hazardous waste.

The above review of organic compounds has been very brief and is not designed to address details contained in texts on organic or environmental chemistry. More details on organic compounds, their degradation, and reactions in ground water can be found in Sawyer, McCarty, and Parkin (1994), Pankow and Cherry (1996), Fetter (1999), and Manahan (1991). Chapter 7 presents important chemical reactions, adsorption processes, and biodegradation mechanisms that affect organic contaminants in the subsurface.

## 4.12 INORGANIC COMPOUNDS IN GROUND WATER

The quality of water is a direct result of the reactions that occur between sources of contamination and other compounds that it may contact. In ground water, chemistry and chemical processes are important primarily because ground water is in contact with soil and rocks that contain a variety of minerals. In addition, the carbon and the nitrogen cycles contribute greatly to the quality of ground water. For instance, rainfall may come in contact with high levels of carbon dioxide in the atmosphere and become acidic. There is potential for this acidic water to infiltrate to ground water and dissolve minerals as it encounters them. Because of the processes that affect it, ground water naturally contains dissolved inorganic ions. A list of major and minor inorganic constituents and trace metals of ground water is presented in Table 4.7.

TABLE 4.7 Dissolved Constituents in Ground Water Classified According to Relative Abundance.

Major Constituents (greater than 5 mg/L)	
Bicarbonate	Magnesium
Calcium	Silicon
Carbonic Acid	Sodium
Chloride	Sulfate
Minor Constituents (0.1–5.0 mg/L)	
Boron	Nitrate
Carbonate	Potassium
Fluoride	Strontium
Iron	
Trace Constituents (less than 0.1 mg/L)	
Aluminum	Lithium
Antimony	Manganese
Arsenic	Molybdenum
Barium	Nickel
Beryllium	Phosphate
Bromide	Radium
Cadmium	Selenium
Cesium	Silver
Chromium	Tin
Copper	Uranium
Iodine	Zinc
Lead	

Chemical parameters of particular importance to ground water constituents and contaminants include solubility product, pH, and oxidation-reduction reactions (Chapter 7). More detailed information may be found in Freeze and Cherry (1979), Domenico and Schwartz (1998), and Fetter (1999), or in Environmental Chemistry texts such as Manahan (1991) or Sawyer, McCarty, and Parkin (1994).

Of the inorganic contaminants in ground water, those of greatest concern are nitrates, ammonia, and trace metals. Nitrates in ground water originate from nitrate sources on land and are associated with fertilizers and the disposal of sewage waste, especially associated with faulty septic tanks. Feedlots are also a major source of nitrate in ground water, especially in rural areas. Nitrate concentrations are not limited by solubility constraints, resulting in high mobility of nitrates in ground water. It has been known since 1940 that ground waters containing high nitrate levels could cause methemoglobinemia in infants, and based on data from the mid-western U.S., EPA set the limit for nitrate-N not to exceed 10 mg/L in public water supplies.

Arsenic, cadmium, chromium, lead, zinc, and mercury are metal pollutants of major concern in ground water. Most of them arise from industrial practices and discharges from mining, metal plating, plumbing, coal, gasoline, and pesticide related industries. Many of these metals are very toxic to humans, especially cadmium, lead, and mercury. Cadmium and zinc are common water and sediment pollutants in areas associated with industrial installations. A major source of lead comes from leaded gasoline and lead piping. Mercury is associated with discarded batteries, laboratory products, and lawn fungicides. Arsenic is produced through phosphate mining and is a by-product of copper, gold, and lead refining.

These metals are of concern in ground water due to their unique acid-base and solubility characteristics in aerobic systems. Metals occur as cations in ground water of low pH and have a greater mobility in acidic waters. Mobility tends to decrease as the solid phase is approached. Mobility of metals is also increased by complexation of ions, and nearly all the trace metals in ground water are influenced by redox conditions, especially when complexation occurs. Heavy metals are particularly toxic in their chemically combined forms and some, notably mercury, are toxic in the elemental form.

Chromium is perhaps the most mobile of all metals in ground water, and contaminant plumes have been identified and sampled at a number of industrial facilities where metal plating was a predominant activity. A classic plume on Long Island, New York, was reported and modeled by Wilson and Miller (1978). More recently the U.S. Air Force Hughes Plant 44 Site in Tucson, Arizona had a major chromium plume migrating more than 150 ft below the surface in a sand and gravel aquifer, but most of it was remediated via a pump and treat system.

#### 4.13 A TYPICAL INDUSTRIAL WASTE SITE

A typical abandoned industrial site, which has source areas that are leaking organic contaminants, is shown in Figure 4.16. Possible source areas consist of a process area for chemicals

and wastes, drum storage areas, an old drum burial area, an unlined landfill for solid and liquid wastes, surface pits, an injection well for liquid wastes and brines, and leaking industrial sewer lines. A great deal of effort was expended in the 1980s searching aerial photographs, state permit records, and ground water quality records to find active and abandoned industrial waste sites. Many of the older or abandoned sites that were eventually put on the Superfund list resembled the site shown in Figure 4.16. The presence of surface pits or impoundments, drums stored above ground, distressed vegetation from contaminated runoff, and fish kills in surface streams were all indicators of a serious problem at the site.

Source areas often leaked out organic and hazardous contaminants into shallow subsurface aquifers. Because of the slow rate of velocity in ground water compared to surface water (ft/day vs. ft/sec), it can take years or decades for contaminant plumes to migrate from a source area to a receptor off-site where contamination is first observed.

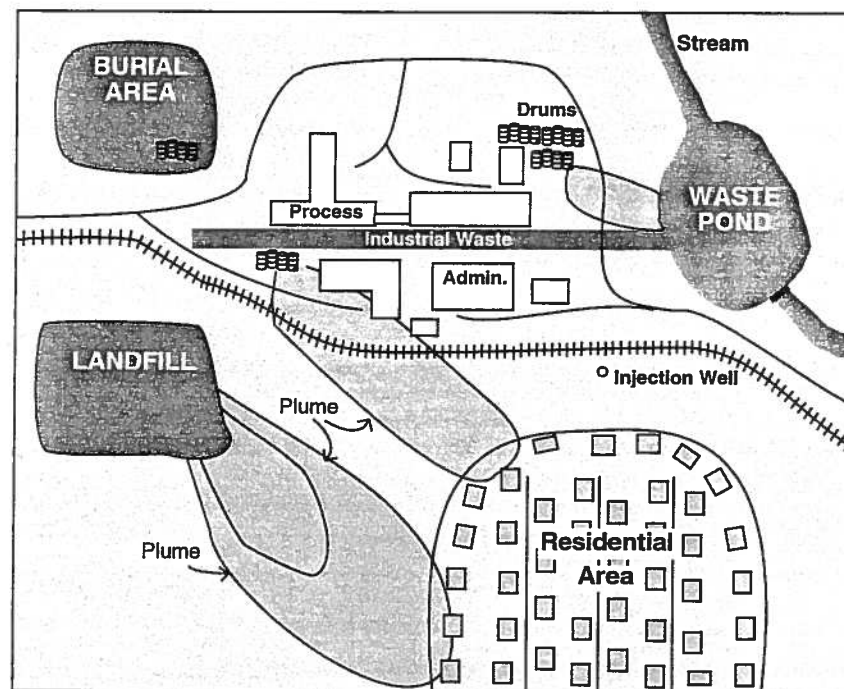

Figure 4.16 Typical contaminated industrial site.

Plumes of contamination are often associated with leaking drums, landfills, burial areas, ponds, and leaking pipe systems. Oftentimes, these plumes can extend for hundreds or thousands of feet from the source area, and impact neighborhoods, commercial areas, or receiving streams. Note the ground water plumes emanating from the process area, the landfill, and the drum storage areas. In the 1980s, these plumes became the subject of intense investigation and remedial activity, designed to cleanup shallow aquifers that had been contaminated with organics. Many of the hazardous waste sites were discovered when contaminant plumes finally arrived at receptor wells or impacted surface streams.

Mechanisms of transport in the subsurface include vertical migration through the unsaturated zone, advection and dispersion in the saturated zone, adsorption to soils, and possibly biodegradation under the right chemical conditions (see Chapters 6, 7 and 8). The most commonly found organic contaminants in ground water from industrial sites include the most mobile and soluble of the compounds listed in Table 4.3 and Table 7.1 in Chapter 7. These primarily include the fuel aromatics (benzene, toluene, ethyl benzene, and the xylenes), and chlorinated solvents (PCE, TCE, 1,2-DCE, and others described in Section 4.11). Chapter 5 addresses the investigation of contaminated sites and describes drilling, sampling, and monitoring methods in detail, and Chapter 6 covers transport mechanisms in detail.

## SUMMARY

Chapter 4 has reviewed the main sources and types of ground water contamination. In particular, underground storage tanks, septic tanks, agricultural activities, municipal landfills, military installations, nuclear sites, and abandoned hazardous waste sites are considered major threats to ground water. These are described in some detail in the chapter, with examples indicated for each of the major source categories. The nomenclature and characteristics of the most common organic and inorganic compounds found in ground water are addressed briefly in this chapter; other major references on organic and inorganic compounds include Sawyer, McCarty, and Parkin (1994), Pankow and Cherry (1996), and Fetter (1999).

## REFERENCES

- Bedient, P. B., A. W. Holder, C. G. Enfield, and A. L. Wood, "Enhanced Remediation Demonstrations at Hill AFB: Introduction," in American Chemical Society Symposium Series Volume, *Field Testing of Innovative Subsurface Remediation and Characterization Technologies*, 1999
- Bureau of Economic Geology, "Extent, Mass, and Duration of Hydrocarbon Plumes from LPSTs in Texas," Austin, Texas, 1997.
- Department of Energy, "Closing the Circle on the Splitting of the Atom," Washington, DC, 1995.
- Domenico, P. A. and F. W. Schwartz, *Physical and Chemical Hydrogeology*, 2nd Ed., New York, John Wiley and Sons, 1998.

- El-Beshry, M. Z., J. S. Gierke, and P. B. Bedient, "Comparison of Predictions of a 3-Dimensional Numerical Simulator to Data from a Full-Scale Soil Vapor Extraction System at a Jet-Fuel Contaminated Site," submitted to the *ASCE Journal of Environmental Eng.*, May 1998.
- Fetter, C.W., *Applied Hydrogeology*, 3rd ed. Columbus, OH, Merrill Publishing Company, 1994.
- Fetter, C.W., *Contaminant Hydrogeology*, 2nd Ed., Upper Saddle River, NJ, Prentice Hall, 1999.
- Freeze, R. A., and J. A. Cherry, *Groundwater*, Englewood Cliffs, NJ, Prentice-Hall, 1979.
- Harr, Jonathan, *A Civil Action*, New York, First Vintage Books, 1996.
- Hirasaki, G. J., C. A. Miller, R. Szafranski, J. B. Lawson, and N. Akiya, "Surfactant Foam Process for Aquifer Remediation," SPE paper no. 37257, presented at the SPE International Symposium on Oil Field Chemistry, Houston, TX, February 18-21, 1997.
- Jorgensen, E. P., Ed., *The Poisoned Well*, Chapter 3, Washington, D.C., Island Press, 1989.
- Konikow, L. F., D. W. Thompson, "Groundwater Contamination and Aquifer Reclamation at the Rocky Mountain Arsenal, Colorado," *Studies in Geophysics, Groundwater Contamination*, Washington, D.C., National Academy Press, 1984.
- Lawrence Berkeley Laboratories, California LUFT Historical Case Analyses, 1995.
- Manahan, S. E., *Environmental Chemistry*, 5th ed., Chelsea, MI, Lewis Publishers, 1991.
- Office of Technology Assessment (OTA), *Protecting the Nation's Groundwater from Contamination*, Report, 1984.
- Pankow, J. F., *Aquatic Chemistry Concepts*, Chelsea, MI, Lewis Publishers, 1991.
- Pankow, J. F. and J. A. Cherry, *Dense Chlorinated Solvents*, Canada, Waterloo Press, 1996.
- Rao, P. S. C., M. D. Annable, R. K. Sillan, D. Dai, K. Hatfield, W. D. Graham, A. L. Wood, and C. G. Enfield, "Field-Scale Evaluation of In Situ Cosolvent Flushing for Enhanced Aquifer Remediation," *Water Resources Res.*, 33 (12), 2673-2686, 1997.
- Sabatini, D. A., J. H. Harwell, and R. C. Knox, "Surfactant Selection Criteria for Enhanced Subsurface Remediation," Brusseau et al., eds., *Innovative Subsurface Remediation: Field Testing of Physical, Chemical and Characterization Technologies*, ACS Symposium Series, in press, 1999.
- Sawyer, C. N., P. L. McCarty, and G. F. Parkin, *Chemistry for Environmental Engineering*, 4th Ed., New York, McGraw Hill, 1994.
- Schwarzenbach, R. P., P. M. Gschwend, and D. M. Imboden, *Environmental Organic Chemistry*, New York, John S. Wiley and Sons, 1993.
- U.S. EPA, the National Water Quality Inventory - 1988 Report to Congress, 1990.
- Wilson, J. D. and P. J. Miller, April, "Two-Dimensional Plume in Uniform Ground-Water Flow," *Journal of the Hydraulics Division*, 1978.
- Zheng, C. and G. D. Bennett, *Applied Contaminant Transport Modeling: Theory and Practice*, New York, Van Nostrand Reinhold, 1995.