



# CE 3372 WATER SYSTEMS DESIGN

LESSON 12: OPEN CHANNEL FLOW (GRADUALLY VARIED FLOW)

# FLOW IN OPEN CONDUITS

- Gradually Varied Flow Hydraulics
  - Principles
  - Resistance Equations
  - Specific Energy
  - Subcritical, critical, supercritical and normal flow.



# DESCRIPTION OF FLOW

- Open channels are conduits whose upper boundary of flow is the **liquid surface**.
- **Storm sewers** and **sanitary sewers** are typically designed to operate as open channels.
- The relevant hydraulic principles are the concept of friction, gravitational, and pressure forces.

## DESCRIPTION OF FLOW

- For a given discharge,  $Q$ , the flow at any section can be described by the flow depth, cross section area, elevation, and mean section velocity.
- The flow-depth relationship is non-unique, and knowledge of the flow type is relevant.

# OPEN CHANNEL NOMENCLATURE

- Flow depth is the depth of flow at a station (section) measured from the channel bottom.

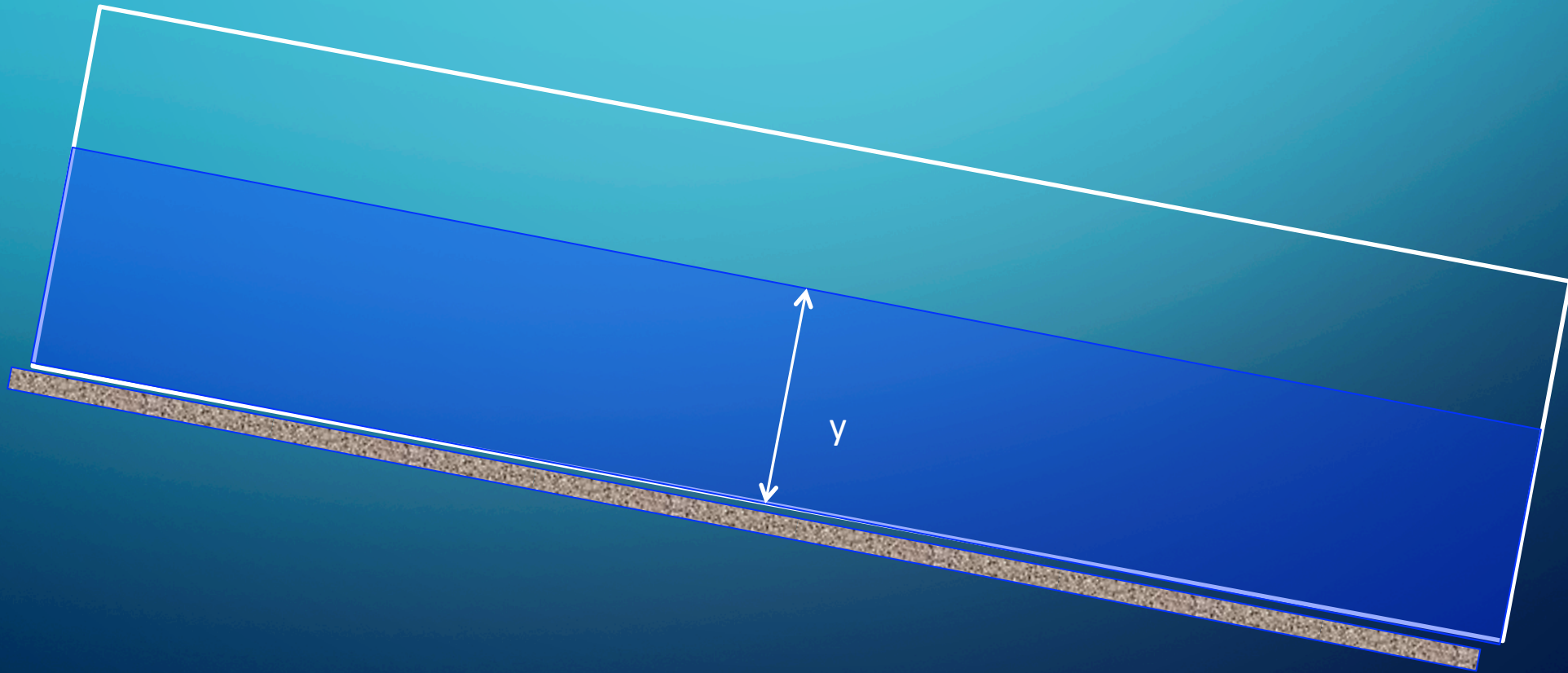



# OPEN CHANNEL NOMENCLATURE

- Elevation of the channel bottom is the elevation at a station (section) measured from a reference datum (typically MSL).

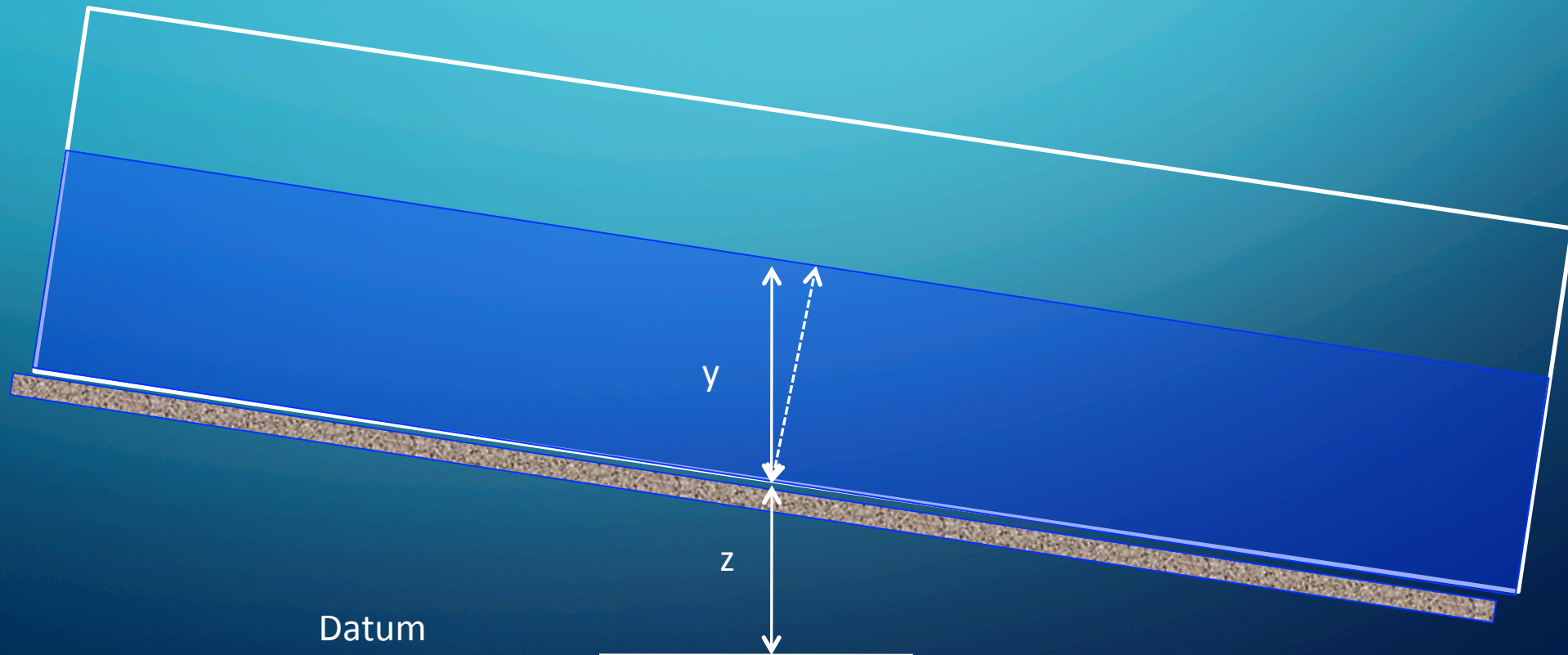

# OPEN CHANNEL NOMENCLATURE

- Slope of the channel bottom is called the topographic slope (or channel slope).

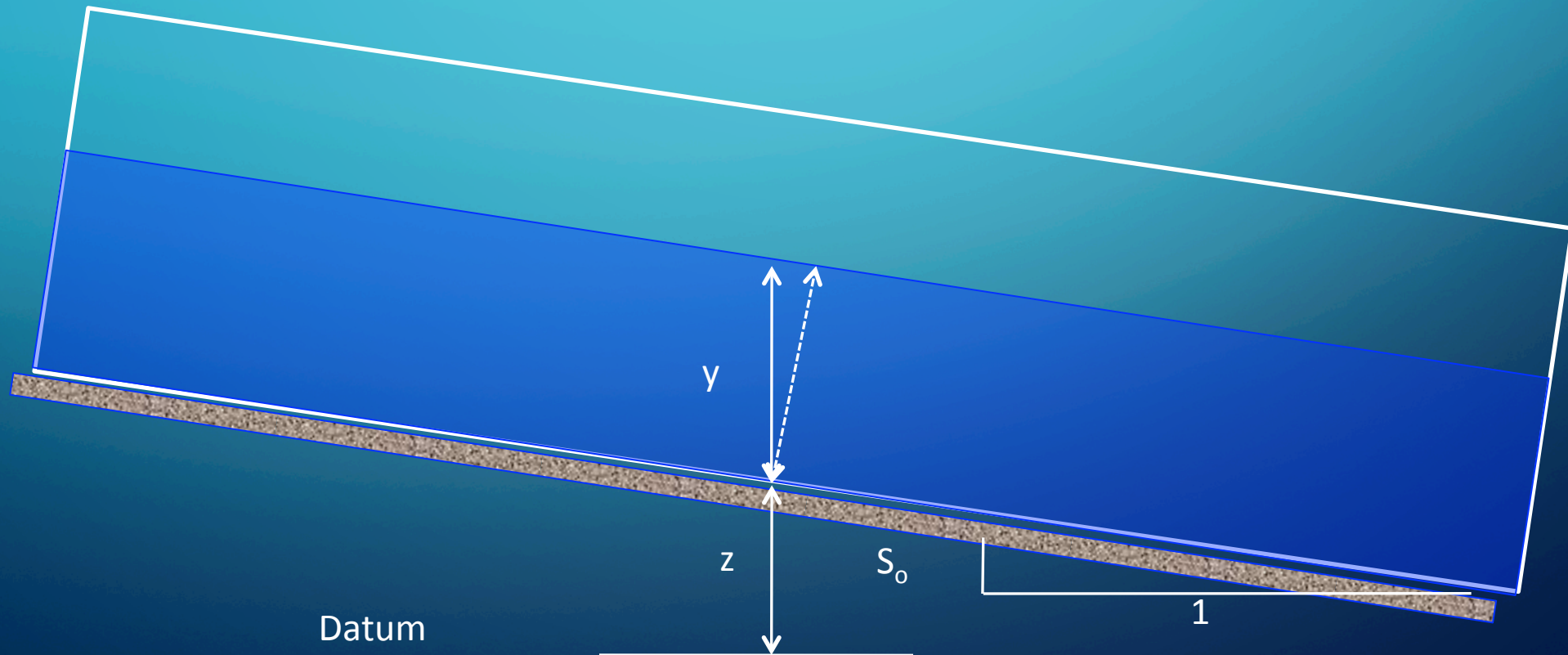

# OPEN CHANNEL NOMENCLATURE

- Slope of the water surface is the slope of the HGL, or slope of WSE (water surface elevation).

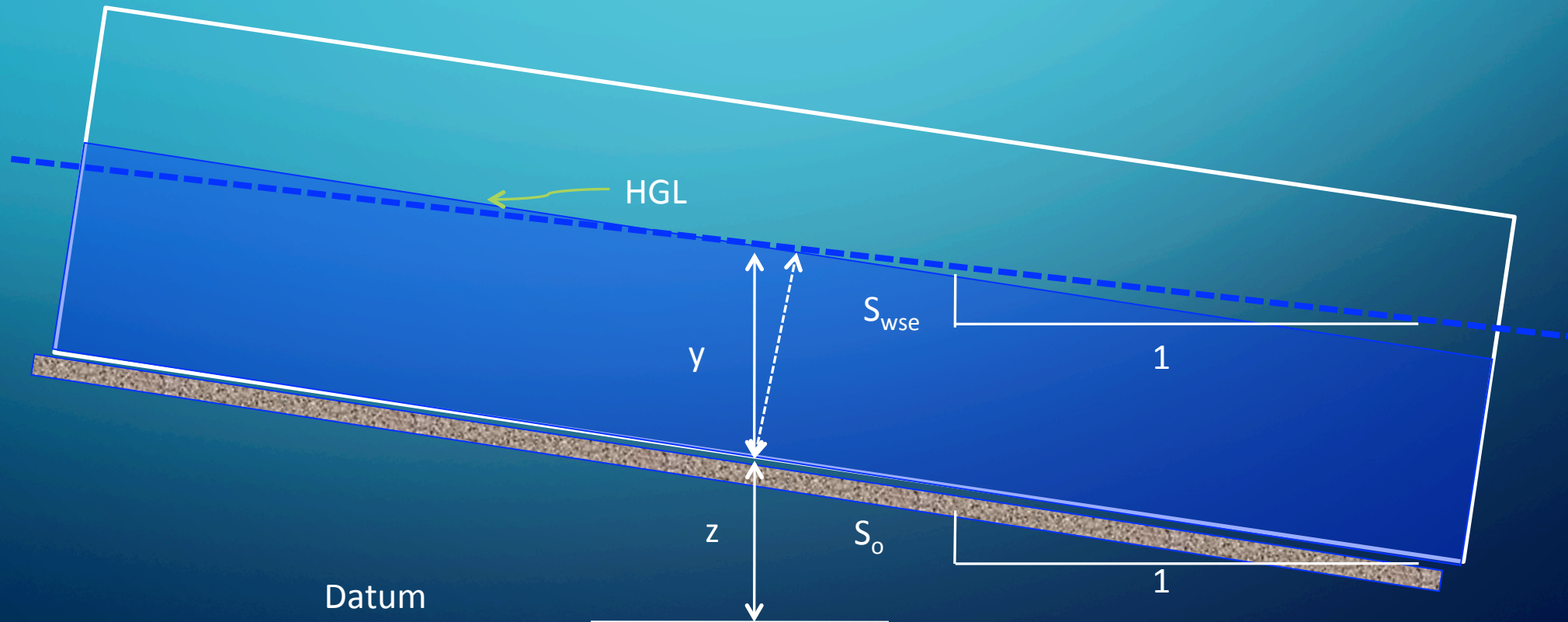



# OPEN CHANNEL NOMENCLATURE

- Slope of the energy grade line (EGL) is called the energy or friction slope.

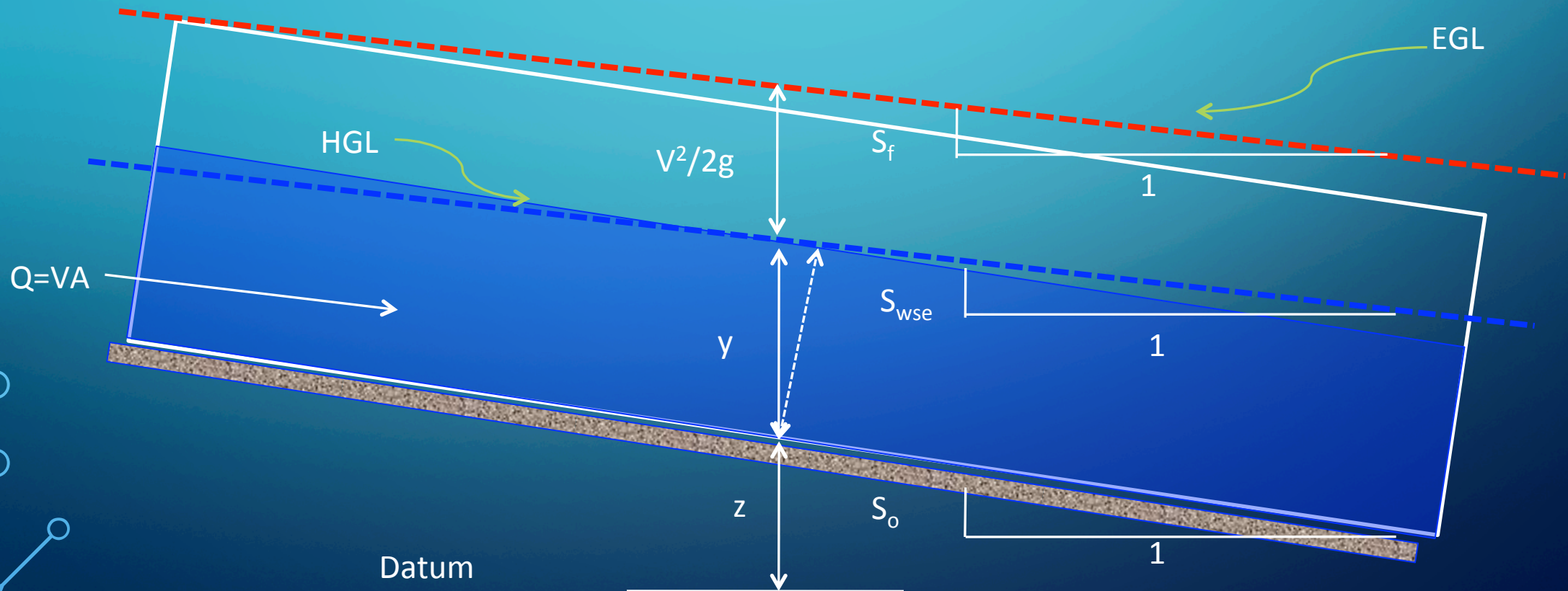

# OPEN CHANNEL NOMENCLATURE

- Like closed conduits, the various terms are part of mass, momentum, and energy balances.
- Unlike closed conduits, geometry is flow dependent, and the pressure term is replaced with flow depth.

# OPEN CHANNEL NOMENCLATURE

- Open channel pressure head:  $y$
- Open channel velocity head:  $V^2/2g$   
(or  $Q^2/2gA^2$ )
- Open channel elevation head:  $z$
- Open channel total head:  $h=y+z+V^2/2g$
- Channel slope:  $S_o = (z_1-z_2)/L$ 
  - Typically positive in the down-gradient direction.
- Friction slope:  $S_f = (h_1-h_2)/L$



# UNIFORM FLOW

- Uniform flow (normal flow; pg 104) is flow in a channel where the depth does not vary along the channel.
- In uniform flow the slope of the water surface would be expected to be the same as the slope of the bottom surface.

# UNIFORM FLOW

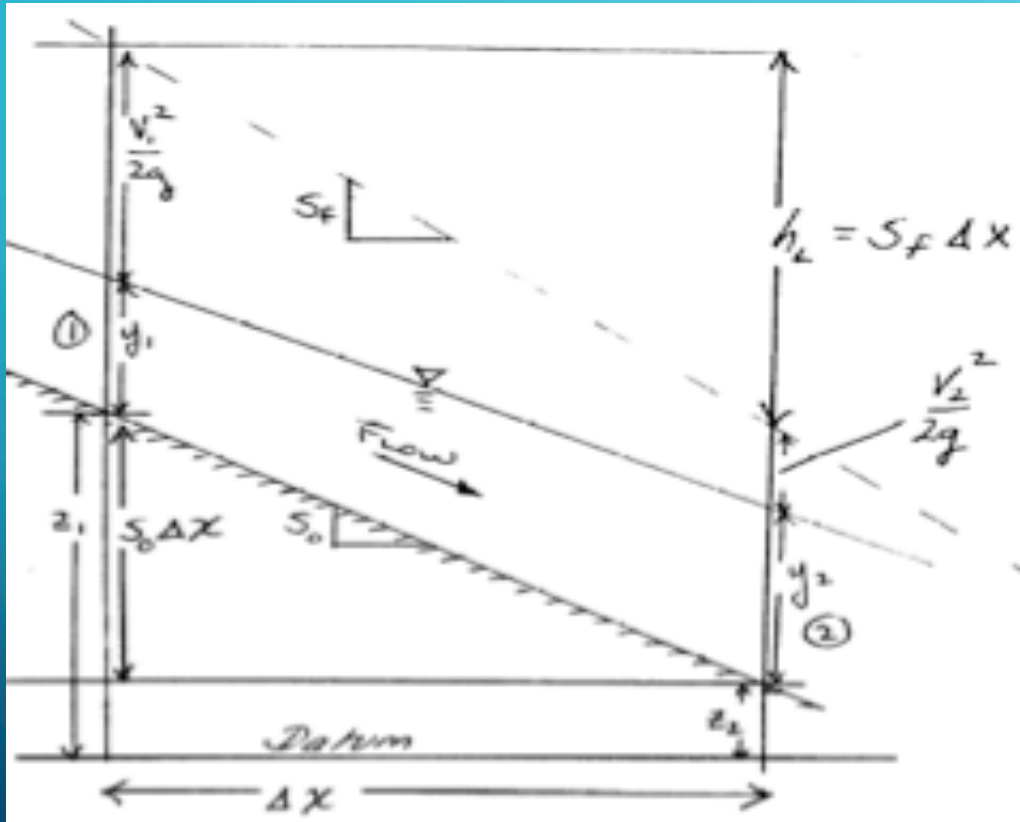

- Uniform flow would occur when the two flow depths  $y_1$  and  $y_2$  are equal.
- In that situation:
  - the velocity terms would also be equal.
  - the friction slope would be the same as the bottom slope.

Sketch of gradually varied flow.

# GRADUALLY VARIED FLOW

- Gradually varied flow means that the change in flow depth moving upstream or downstream is gradual (i.e. NOT A WATERFALL!).
  - The water surface is the hydraulic grade line (HGL).
  - The energy surface is the energy grade line (EGL).



# GRADUALLY VARIED FLOW

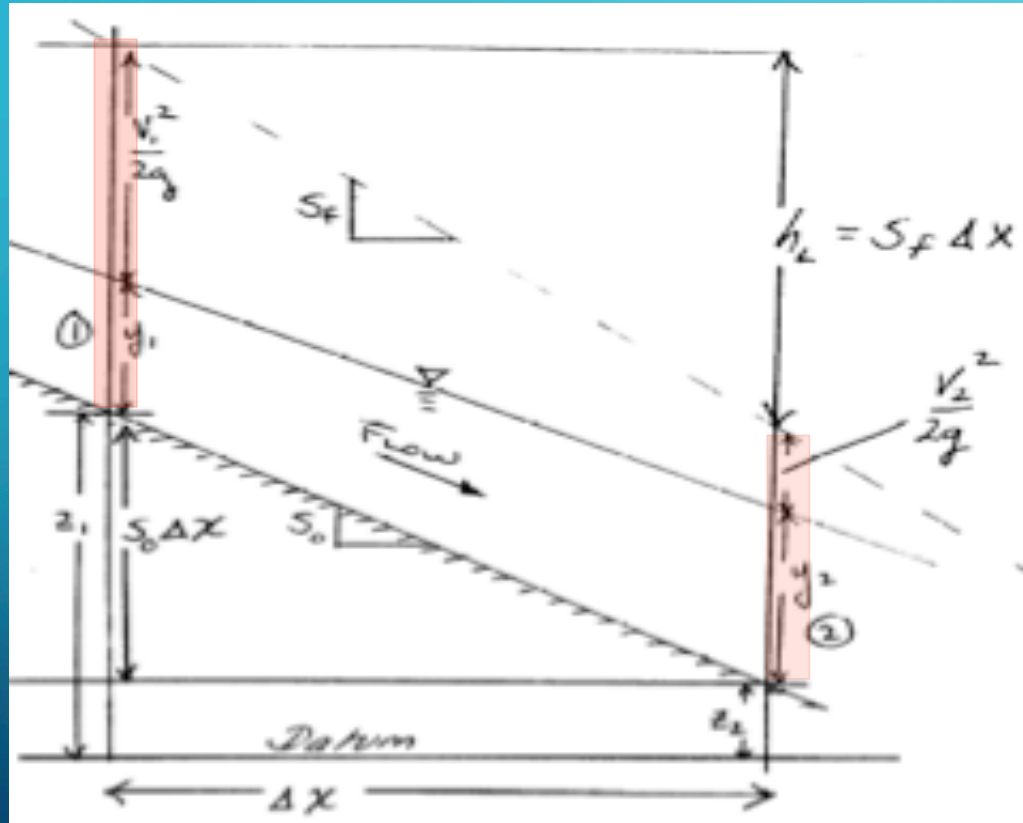

- Energy equation has two components, a specific energy and the elevation energy.

Energy Equation from ① → ②

$$\underbrace{\frac{v_1^2}{2g} + y_1 + z_1}_{E_1} = \underbrace{\frac{v_2^2}{2g} + y_2 + z_2}_{E_2} + h_L$$

- Specific energy at each section

Sketch of gradually varied flow.

# GRADUALLY VARIED FLOW

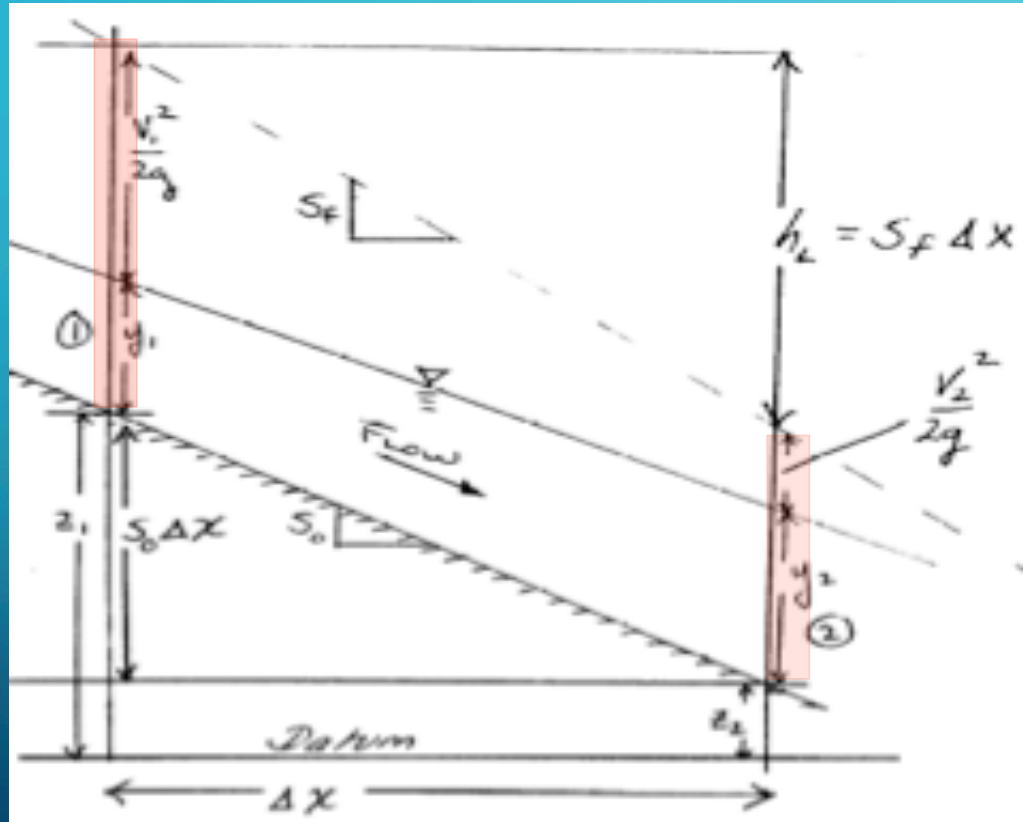

- Energy equation has two components, a specific energy and the elevation energy.

$$\begin{aligned}
 E_1 + (z_1 - z_2) &= E_2 + h_L \\
 &= S_0 \Delta X \qquad \qquad S_f \Delta X \\
 \therefore E_1 + S_0 \Delta X &= E_2 + S_f \Delta X
 \end{aligned}$$

Sketch of gradually varied flow.

# GRADUALLY VARIED FLOW

- Energy equation is used to relate flow, geometry and water surface elevation (in GVF)

$$E_1 + S_0 \Delta x = E_2 + S_f \Delta x$$

- The left hand side incorporating channel slope relates to the right hand side incorporating friction slope.



# GRADUALLY VARIED FLOW

- Rearrange a bit

$$S_0 - S_f = \frac{E_2 - E_1}{\Delta x}$$

- In the limit as the spatial dimension vanishes the result is.

$$S_0 - S_f = \frac{dE}{dx}$$

# GRADUALLY VARIED FLOW

- Energy Gradient:

$$S_0 - S_f = \frac{dE}{dx} = \frac{dE}{dy} \frac{dy}{dx}$$

- Depth-Area-Energy
  - (From pp 119-123; considerable algebra is hidden )

$$\frac{dE}{dy} = 1 - \frac{Q^2}{gA^3} \frac{dA}{dy} = 1 - Fr^2$$

# GRADUALLY VARIED FLOW

- Make the substitution:

$$S_0 - S_f = (1 - Fr^2) \frac{dy}{dx}$$

- Rearrange

Variation of  
Water Surface Elevation

$$\frac{dy}{dx} = \frac{S_0 - S_f}{1 - Fr^2}$$

Discharge and  
Section Geometry

Discharge and  
Section Geometry



## GRADUALLY VARIED FLOW

- Basic equation of gradually varied flow
  - It relates slope of the hydraulic grade line to slope of the energy grade line and slope of the bottom grade line.

$$\frac{dy}{dx} = \frac{S_0 - S_f}{1 - Fr^2}$$

- This equation is integrated to find shape of water surface (and hence how full a sewer will become)

# GRADUALLY VARIED FLOW

- Before getting to water surface profiles, critical flow/depth needs to be defined

- Specific energy:

- Function of depth.
- Function of discharge.
- Has a minimum at  $y_c$ .

$$E = y + \frac{Q^2}{2gA^2}$$

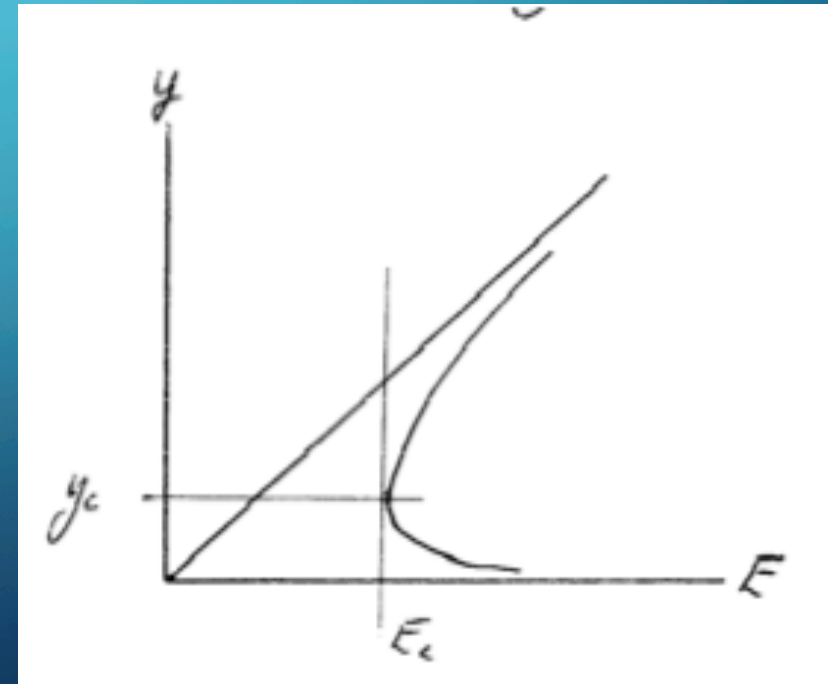
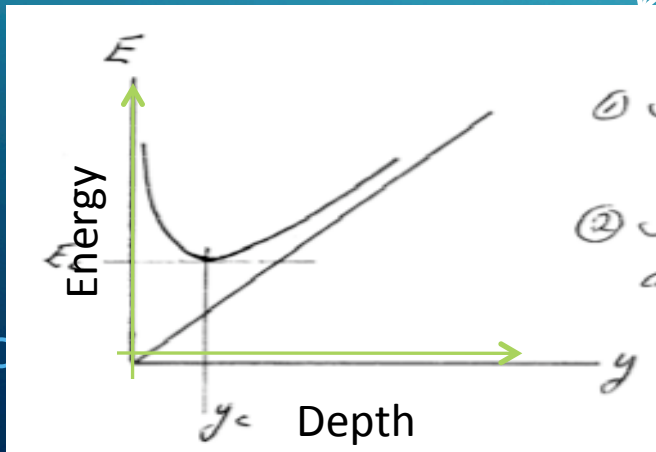

# CRITICAL FLOW

- Has a minimum at  $y_c$ .

$$\left. \frac{dE}{dy} \right|_{y_c} = 0$$

Necessary and sufficient condition for a minimum (gradient must vanish)

$$\frac{dE}{dy} = 1 - \frac{Q^2}{gA^3} \frac{dA}{dy}$$

Variation of energy with respect to depth; Discharge "form"

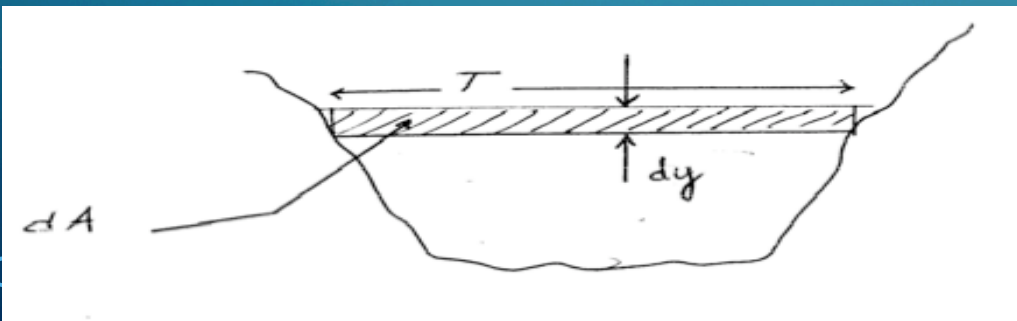

Depth-Area-Topwidth relationship

$$dA = T dy$$



# CRITICAL FLOW

- Has a minimum at  $y_c$ .

$$\frac{dE}{dy} = 1 - \frac{Q^2 T}{g A^3}$$

Variation of energy with respect to depth;  
Discharge “form”, incorporating topwidth.

$$Fr^2 = \frac{Q^2 T}{g A^3}$$

At critical depth the gradient is equal to zero, therefore:

- Right hand term is a squared Froude number. Critical flow occurs when Froude number is unity.
- Froude number is the ratio of inertial (momentum) to gravitational forces

# DEPTH-AREA

- The topwidth and area are depth dependent and geometry dependent functions:

$$T = T(y) \quad (\text{Topwidth is a function of depth})$$

$$A = A(y) \quad (\text{Flow area is a function of depth})$$

# SUPER/SUB CRITICAL FLOW

- Supercritical flow when  $KE > KE_c$ .
- Subcritical flow when  $KE < KE_c$ .
  - Flow regime affects slope of energy gradient, which determines how one integrates to find HGL.

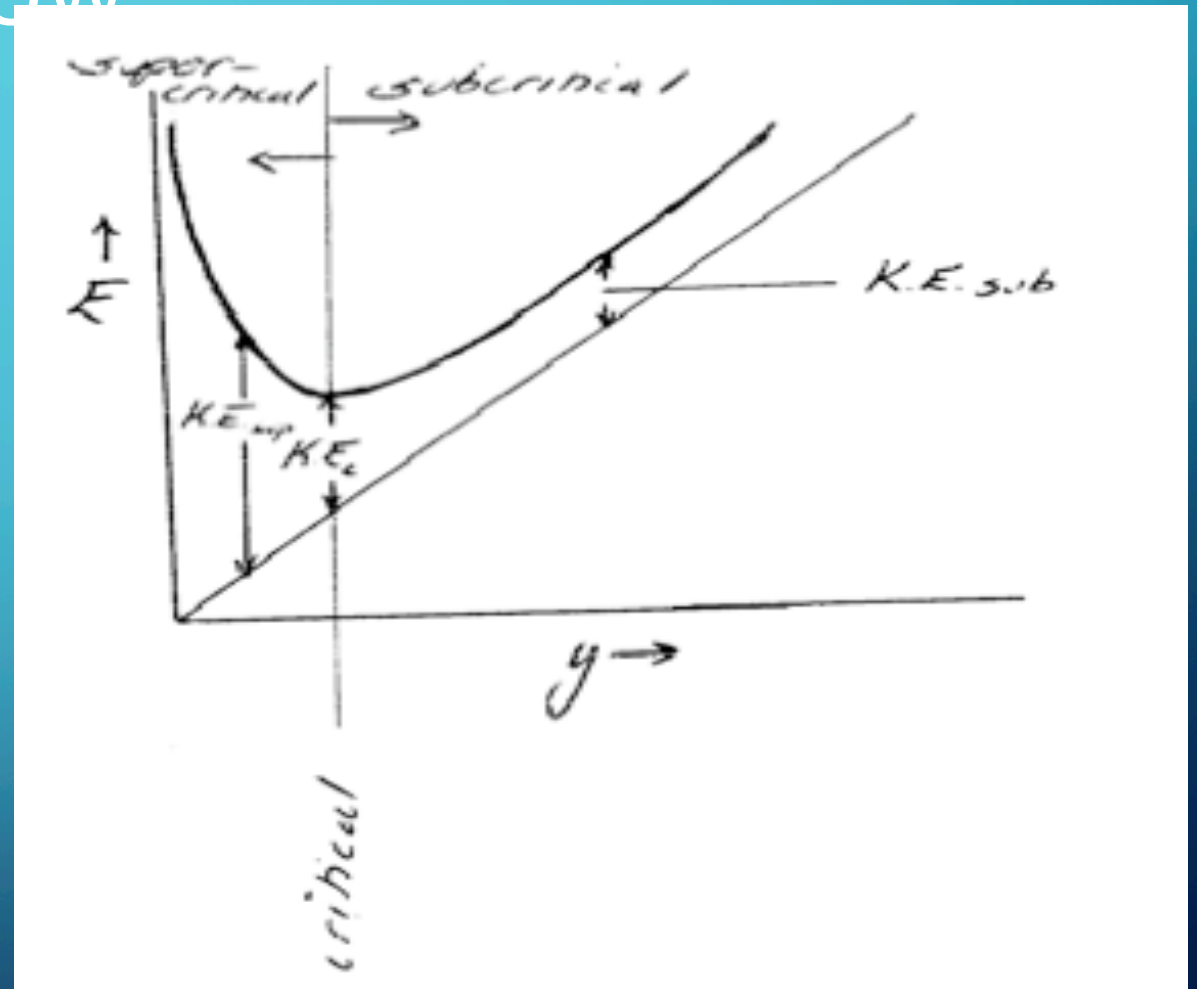



# FINDING CRITICAL DEPTHS

*Consider a rectangular channel*

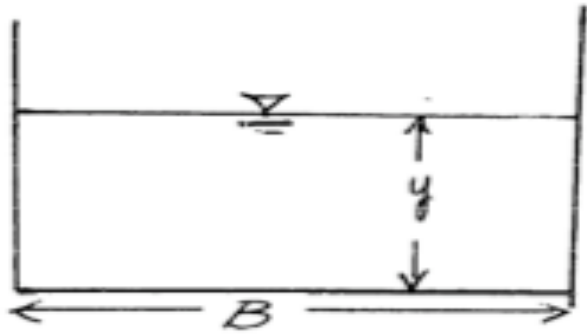

Depth-Area Function:

$$A(y) = By$$

Depth-Topwidth Function:

$$T(y) = B$$

# FINDING CRITICAL DEPTHS

Consider a rectangular channel

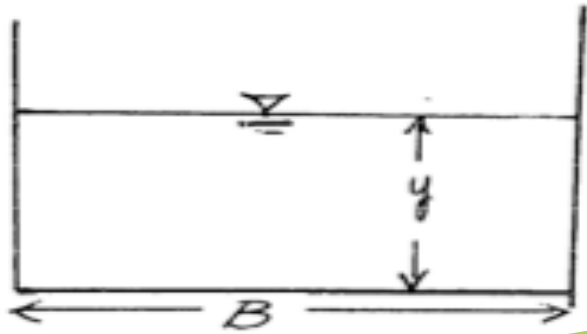

Substitute functions

$$1 = \frac{Q^2 T}{g A^3} = \frac{Q^2 B}{g B^3 y^3} = \frac{Q^2}{g B^2 y^3}$$

$$T(y) = B$$

$$A(y) = By$$

Solve for critical depth

$$y_c = \left( \frac{Q^2}{g B^2} \right)^{1/3}$$

Compare to Eq. 3.104, pg 123)

# FINDING CRITICAL DEPTHS

*Trapezoidal Channel*

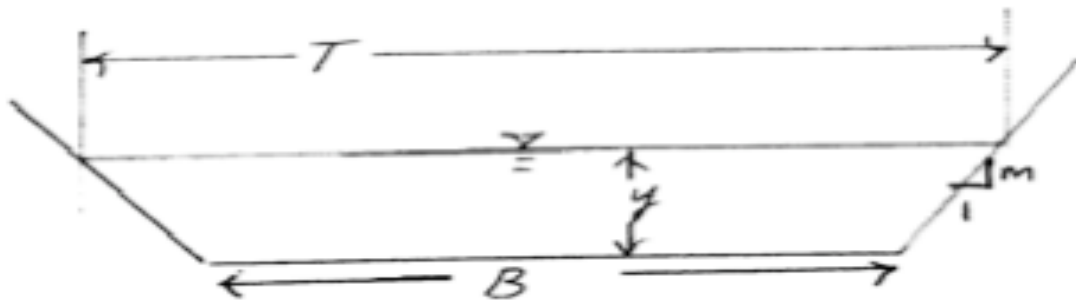

*m-Sideslope*

Depth-Area Function:

$$A(y) = By + y^2/m$$

Depth-Topwidth Function:

$$T(y) = B + \frac{2y}{m}$$



# FINDING CRITICAL DEPTHS

Trapezoidal Channel

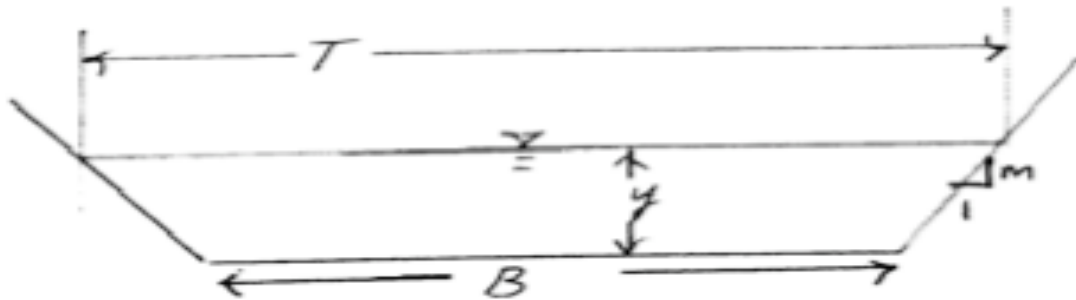

m-Sideslope

Substitute functions

$$1 = \frac{Q^2 T}{g A^3} = \frac{Q^2 (B + \frac{2y}{m})}{g (By + y^2/m)^3}$$

$$T(y) = B + \frac{2y}{m}$$

$$A(y) = By + y^2/m$$

Solve for critical depth,  
By trial-and-error is adequate.

Can use HEC-22 design charts.

# FINDING CRITICAL DEPTHS

Trapezoidal Channel

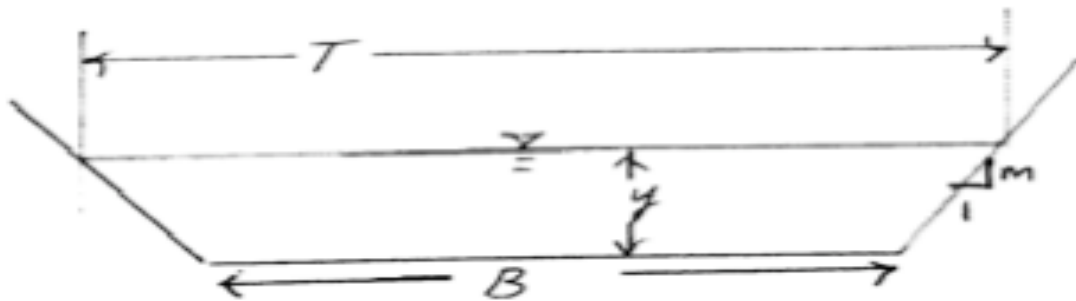

m-Sideslope

trial-and-error:

$$1 = \frac{(500)^2}{32.2} \cdot \frac{(20 + 2y)}{(20y + y^2)^3} = Fr^2(y)$$

$$Q = 500 \text{ ft}^3/\text{s}$$

$$B = 20 \text{ ft}$$

$$m = 1$$

Guess this values

Adjust from Fr

$$1 = \frac{Q^2 T}{g A^3} = \frac{Q^2 (B + \frac{2y}{m})}{g (By + y^2/m)^3}$$

y	$Fr^2(y)$	Remarks
1	18.4	← too big (supercritical)
2	2.2	← too big
3	0.6	← too small (subcritical)
2.5	1.09	← very close
2.56	1.01	← acceptable (critical)

# FINDING CRITICAL DEPTHS

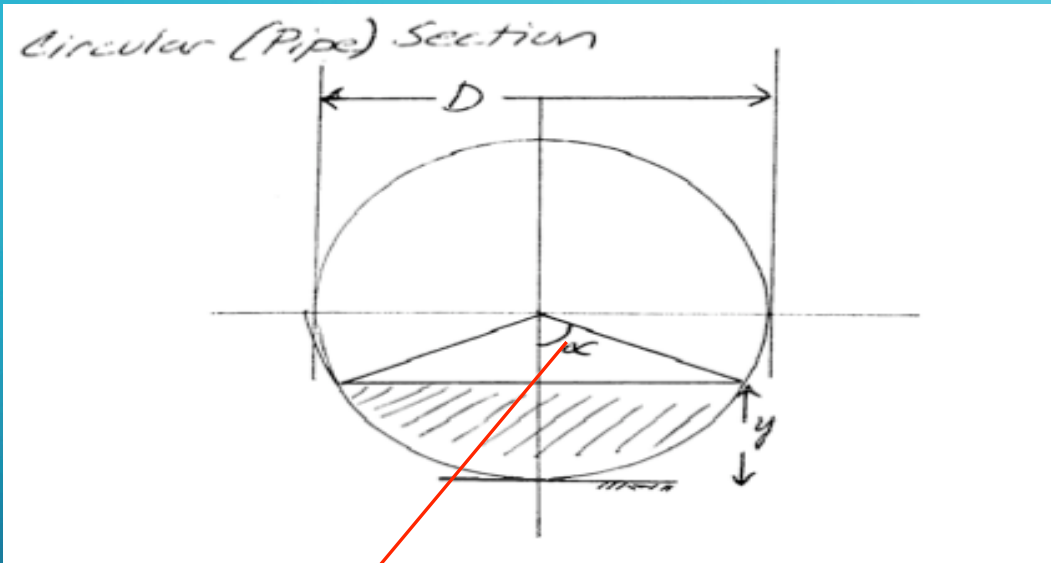

The most common sewer geometry  
(see pp 236-238 for similar development)

Depth-Topwidth:

$$T(y) = D \sin \alpha$$

Depth-Area:

$$A(y) = \frac{D^2}{4} (\alpha - \sin \alpha \cos \alpha)$$

$$\alpha(y) = \cos^{-1} \left( 1 - \frac{2y}{D} \right)$$

Remarks:

Some references use radius and not diameter.

If using radius, the half-angle formulas change.

DON'T mix formulations.

These formulas are easy to derive, be able to do so!



# FINDING CRITICAL DEPTHS

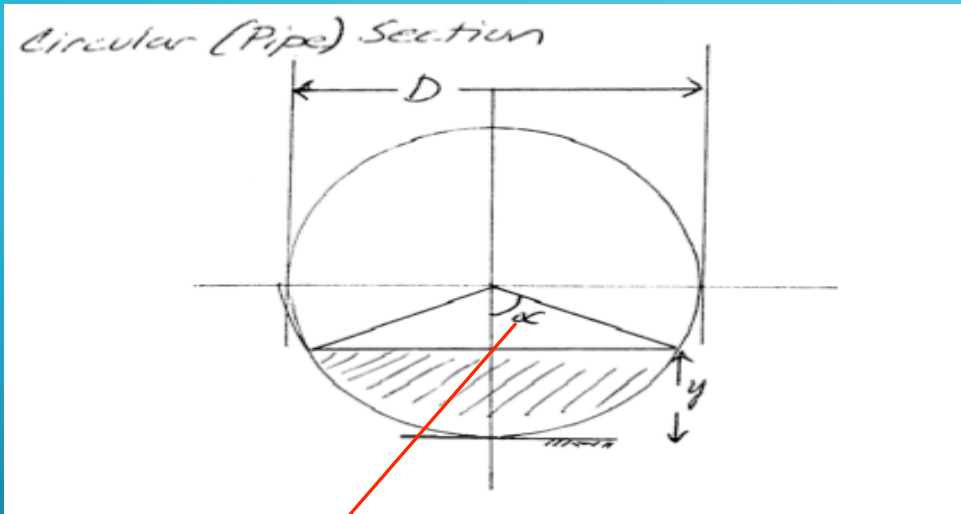

$$\alpha(y) = \cos^{-1}\left(1 - \frac{2y}{D}\right)$$

The most common sewer geometry  
(see pp 236-238 for similar development)

Depth-Topwidth:

$$T(y) = D \sin \alpha$$

Depth-Area:

$$A(y) = \frac{D^2}{4} (\alpha - \sin \alpha \cos \alpha)$$

Depth-Froude Number:

$$Fr^2(y) = \frac{Q^2 D \sin \alpha}{g \left( \frac{D^2}{4} (\alpha - \sin \alpha \cos \alpha) \right)^3}$$

# GRADUALLY VARIED FLOW

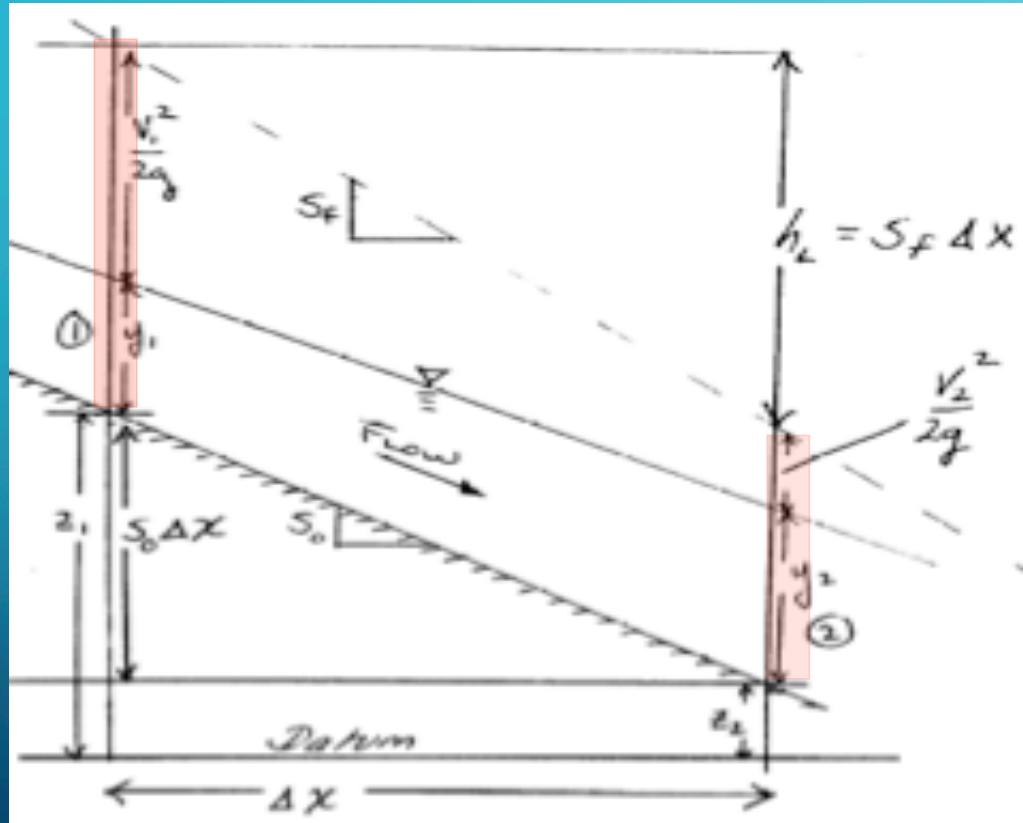

- Energy equation has two components, a specific energy and the elevation energy.

Energy Equation from ① → ②

$$\underbrace{\frac{V_1^2}{2g} + y_1 + z_1}_{E_1} = \underbrace{\frac{V_2^2}{2g} + y_2 + z_2}_{E_2} + h_L$$

- Specific energy at each section

Sketch of gradually varied flow.

# GRADUALLY VARIED FLOW

- Equation relating slope of water surface, channel slope, and energy slope:

$$\frac{dy}{dx} = \frac{S_0 - S_f}{1 - Fr^2}$$

Variation of  
Water Surface Elevation

Discharge and  
Section Geometry

Discharge and  
Section Geometry



# GRADUALLY VARIED FLOW

- Procedure to find water surface profile is to integrate the depth taper with distance:

$$HGL(x) = \int_{x_0}^{x_1} \left( \frac{dy}{dx} \right) + \left( \frac{dz}{dx} \right) dx = \int_{x_0}^{x_1} \frac{S_0 - S_f}{1 - Fr^2} + \left( \frac{dz}{dx} \right) dx$$

# CHANNEL SLOPES AND PROFILES

SLOPE	DEPTH RELATIONSHIP
Steep	$y_n < y_c$
Critical	$y_n = y_c$
Mild	$y_n > y_c$
Horizontal	$S_0 = 0$
Adverse	$S_0 < 0$

PROFILE TYPE	DEPTH RELATIONSHIP
Type-1	$y > y_c$ AND $y > y_n$
Type -2	$y_c < y < y_n$ OR $y_n < y < y_n$
Type -3	$y < y_c$ AND $y < y_n$

# FLOW PROFILES

- All flows approach normal depth
  - M1 profile.
    - Downstream control
    - Backwater curve
    - Flow approaching a “pool”
    - Integrate upstream

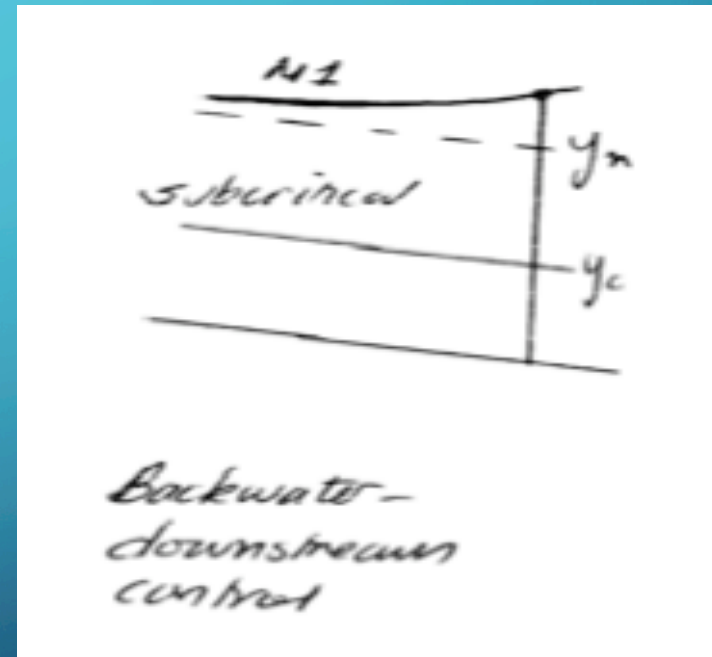



# FLOW PROFILES

- All flows approach normal depth
  - M2 profile.
    - Downstream control
    - Backwater curve
    - Flow accelerating over a change in slope
    - Integrate upstream

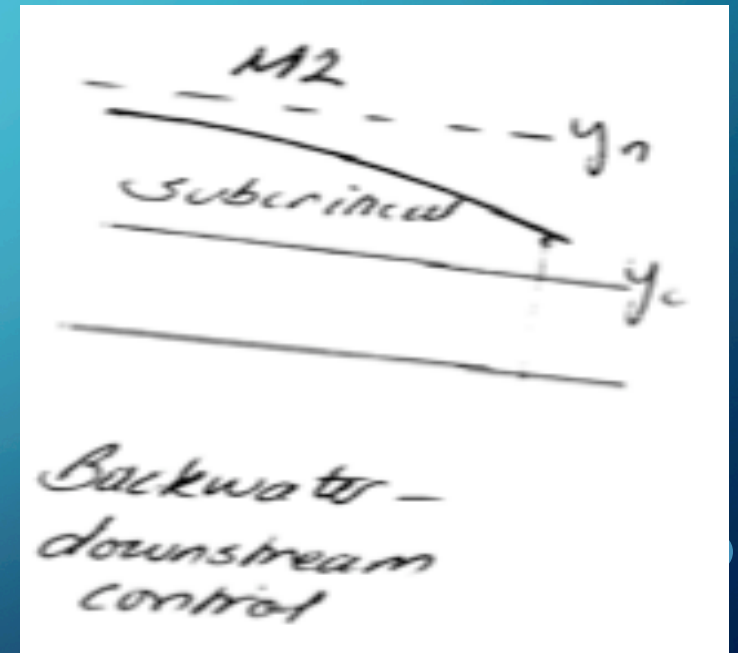

# FLOW PROFILES

- All flows approach normal depth
  - M3 profile.
    - Upstream control
    - Backwater curve
    - Decelerating from under a sluice gate.
    - Integrate downstream

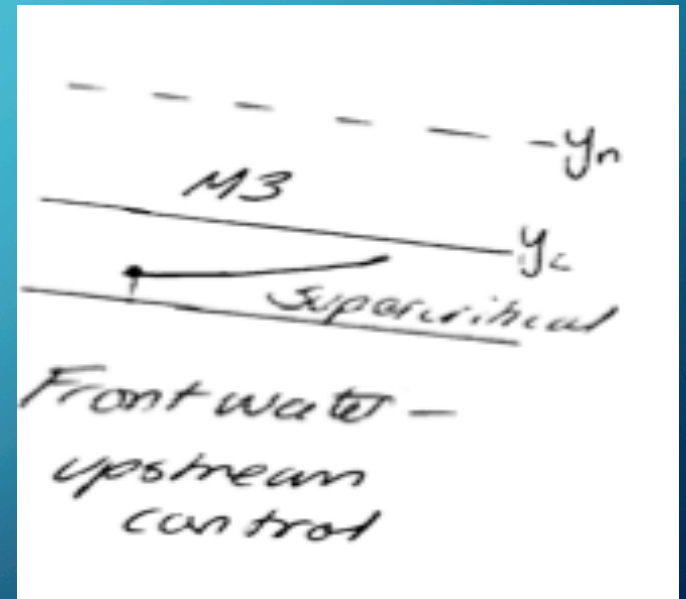

# FLOW PROFILES

- All flows approach normal depth
  - S1 profile.
    - Downstream control
    - Backwater curve
    - Integrate upstream

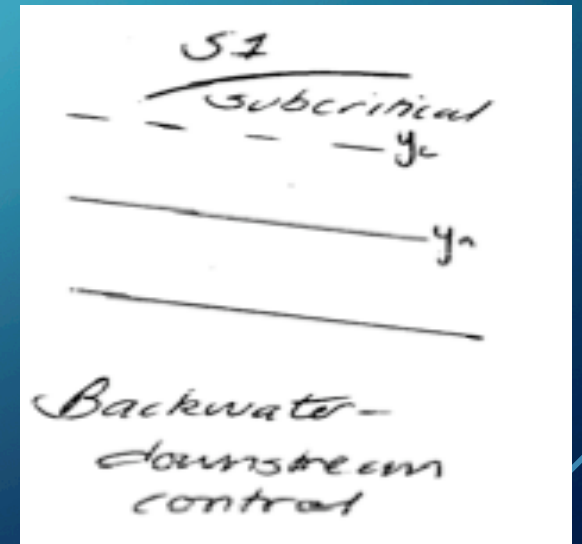



# FLOW PROFILES

- All flows approach normal depth
  - S2 profile.

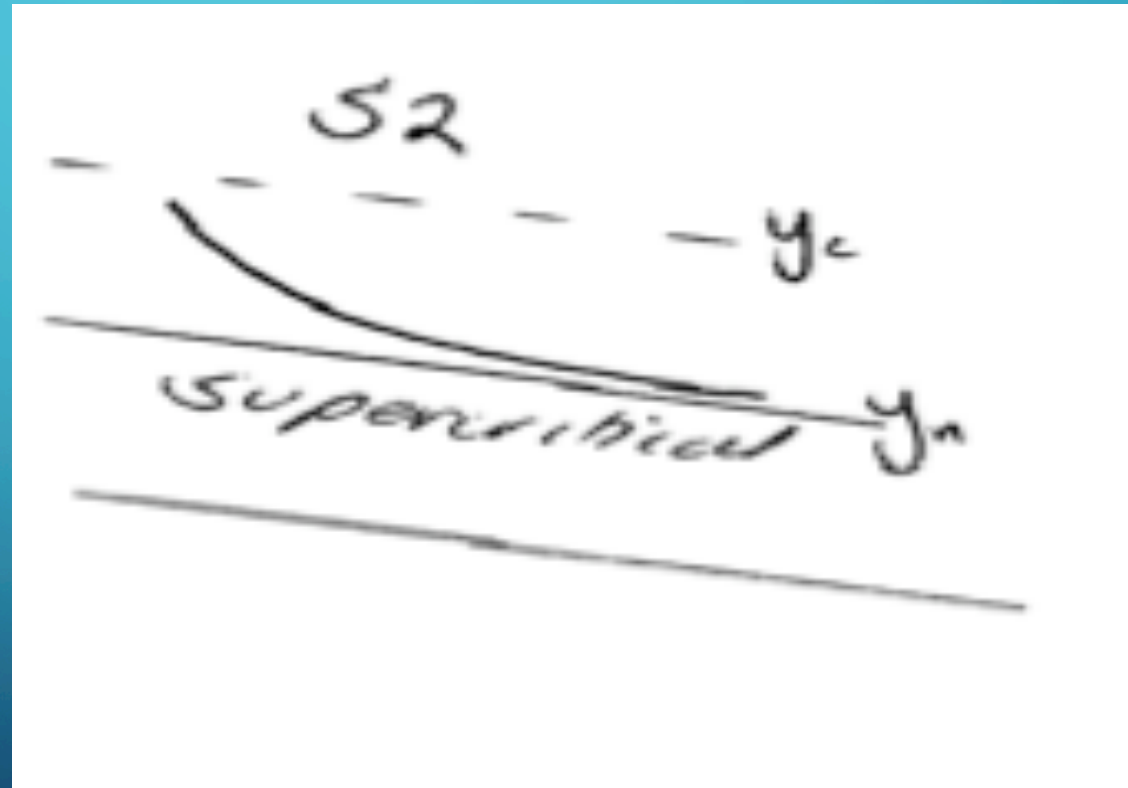

# FLOW PROFILES

- All flows approach normal depth
  - S3 profile.
    - Upstream control
    - Frontwater curve
    - Integrate downstream

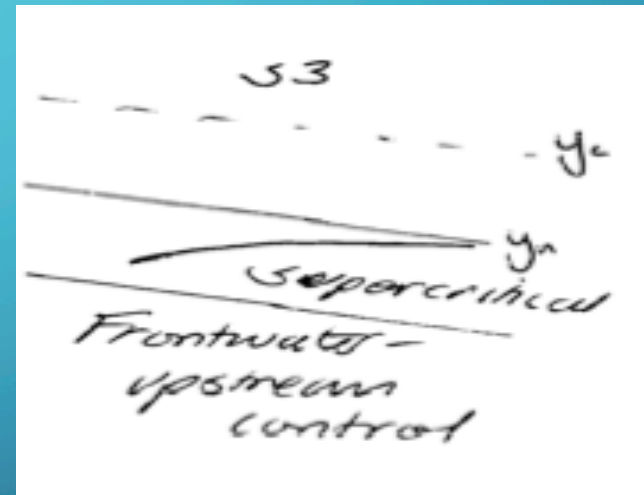

# FLOW PROFILES

- Numerous other examples, see any hydraulics text (Henderson is good choice).
- Flow profiles identify control points to start integration as well as direction to integrate.



# WSP USING ENERGY EQUATION

- Variable Step Method
  - Choose  $y$  values, solve for space step between depths.
    - Non-uniform space steps.
    - Prismatic channels only.

$$E_1 + S_0 \Delta X = E_2 + S_f \Delta X \quad \text{Solve for } \Delta X$$
$$\Delta X = \frac{E_2 - E_1}{S_0 - S_f}$$

# WSP ALGORITHM

- ① Start from a section with known depth.
- ② Calculate  $E_1$  for starting section.
- ③ Calculate  $S_{f_1}$  for starting section
- ④ Perturb depth slightly, calculate new  $E_2$  for new section
- ⑤ Calculate  $S_{f_2}$  at new section
- ⑥ Compute average friction slope  $\bar{S}_f$
- ⑦ Solve for  $\Delta x$ .
- ⑧ Move to next section and repeat

## EXAMPLE

Rectangular Channel,  $B = 1\text{m}$ ,  $Q = 2.5\text{m}^3/\text{s}$   
 $S_0 = 0.001$ ,  $n = 0.025$ . Water flows  
over a weir at  $y = 2.0\text{m}$  just  
upstream of weir. Compute W.S.P.

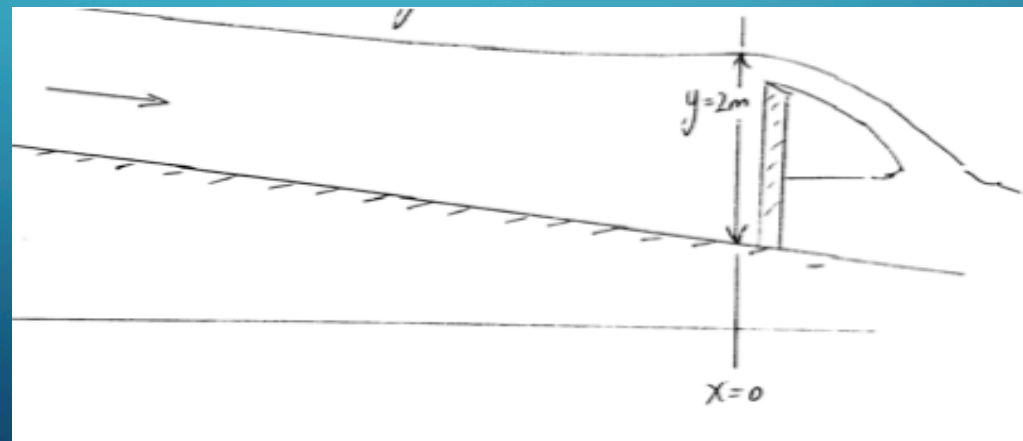



## EXAMPLE

- Energy/depth function

$$E = \frac{Q^2}{2gA^2} + y = \frac{(2.5)^2}{2(9.8)(\ln y)^2} + y = \frac{0.32}{y^2} + y$$

- Friction slope function

$$S_f = \frac{n^2 Q^2}{A^2 R_n^{4/3}} = \frac{n^2 (2.5)^2}{y^2 \left(\frac{y}{1+2y}\right)^{4/3}}$$

## EXAMPLE

- Start at known section

Starting or control section

Section	$y$	$E(y)$	$S_r(y)$	$S_0$	$\Delta X$	$X$
1	2.0	2.079	0.000114	0.001	0	0

- Compute space step (upstream)

$$\Delta X_{1,2} = \frac{1.898 - 2.079}{0.001 - 0.000135} = \frac{-0.181}{0.000865} = -209.3$$

- Enter into table and move upstream and repeat

# EXAMPLE

- Start at known section

Starting or control section

Section	$y$	$E(y)$	$S_r(y)$	$S_0$	$\Delta X$	$X$
1	2.0	2.079	0.000114	0.001	0	0
2	1.8	1.898	0.000157	0.001	-209.3	-209.3

- Compute space step (upstream)

$$\Delta X_{2 \rightarrow 3} = \frac{1.724 - 1.898}{0.001 - 0.000191} = \frac{-0.174}{0.000809} = -215.1$$



# EXAMPLE

- Continue to build the table

Starting or control section

Section	$y$	$E(y)$	$S_r(y)$	$S_o$	$\Delta X$	$X$
1	2.0	2.079	0.000114	0.001	0	0
2	1.8	1.898	0.000157	0.001	-209.3	-209.3
3	1.6	1.724	0.000225	0.001	-215.1	-424.3

# EXAMPLE

- Use tabular values and known bottom elevation to construct WSP.

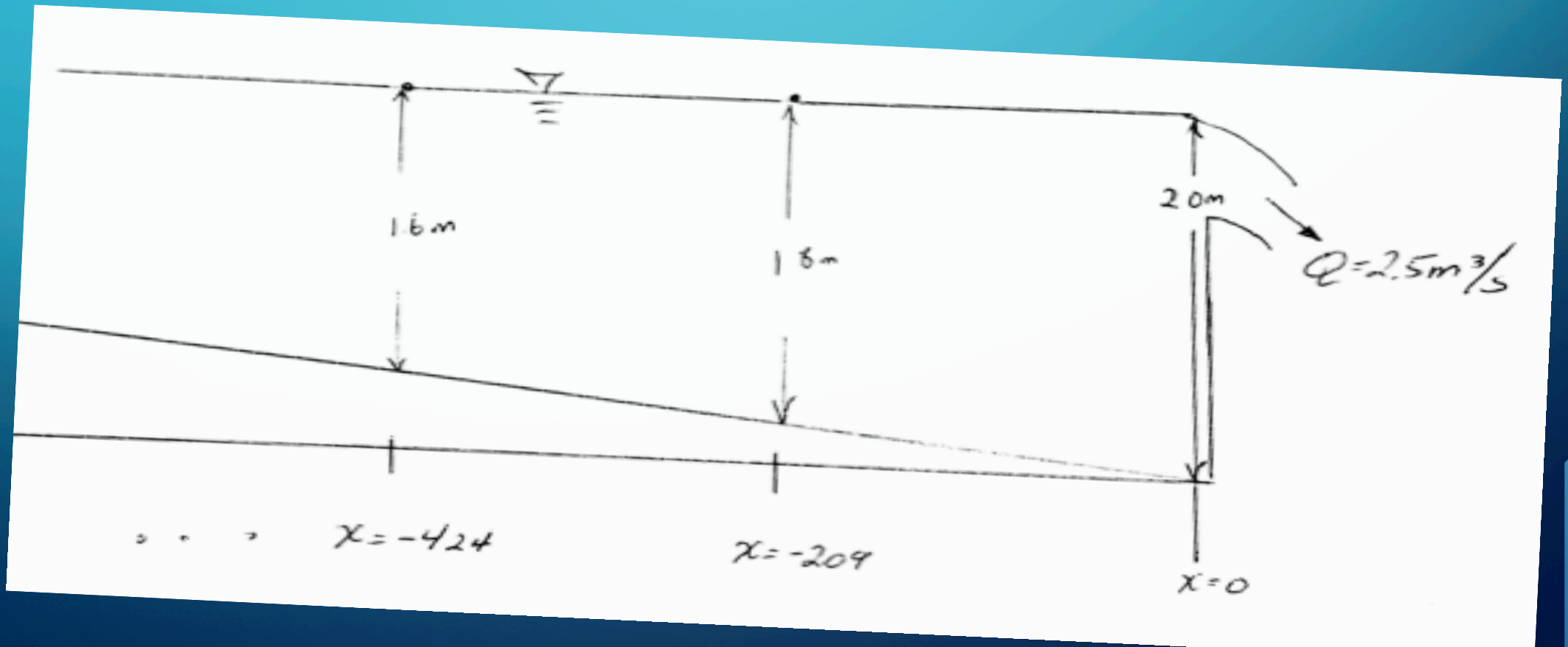

## WSP FIXED STEP METHOD

- Fixed step method rearranges the energy equation differently:

$$E_2 = E_1 + \frac{S_0 - S_f}{\Delta x}$$

- Right hand side and left hand side have the unknown “y” at section 2.
  - Implicit, non-linear difference equation.
  - Use SWMM or HEC-RAS for this (or take Open Channel Flow class)



# GRADUALLY VARIED FLOW

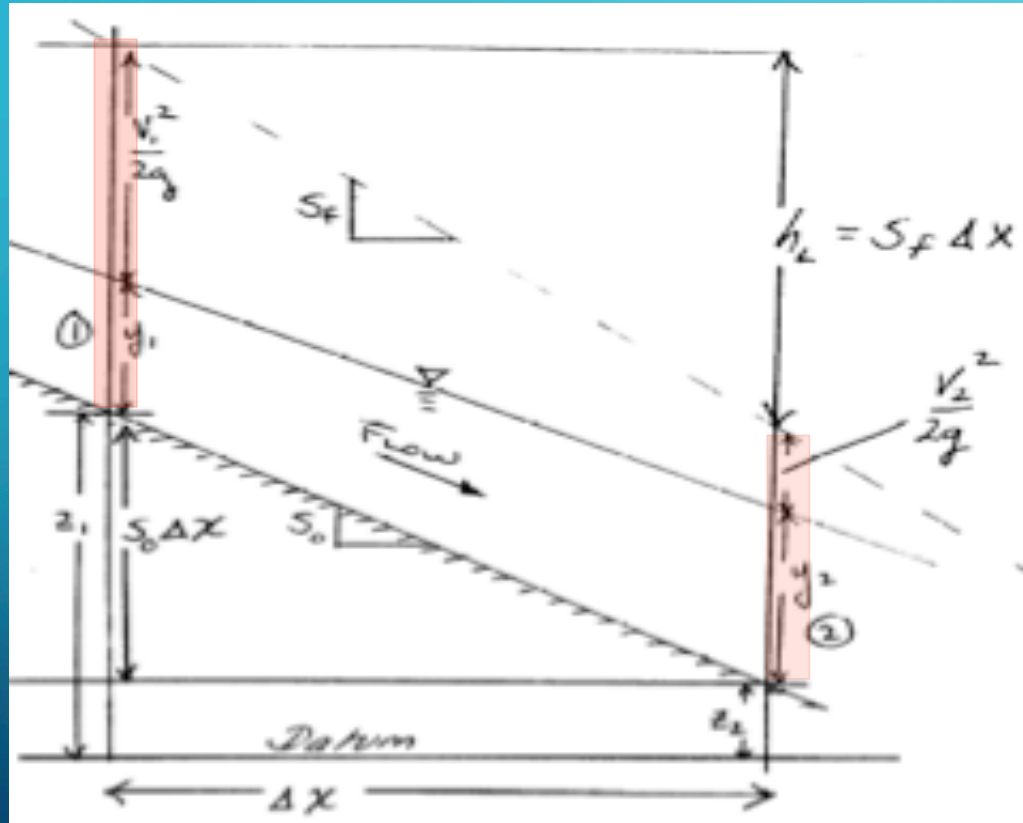

- Apply WSP computation to a circular conduit

Energy Equation from ① → ②

$$\underbrace{\frac{V_1^2}{2g} + y_1 + z_1}_{E_1} = \underbrace{\frac{V_2^2}{2g} + y_2 + z_2}_{E_2} + h_L$$

- Specific energy at each section

Sketch of gradually varied flow.

# DEPTH-AREA RELATIONSHIP

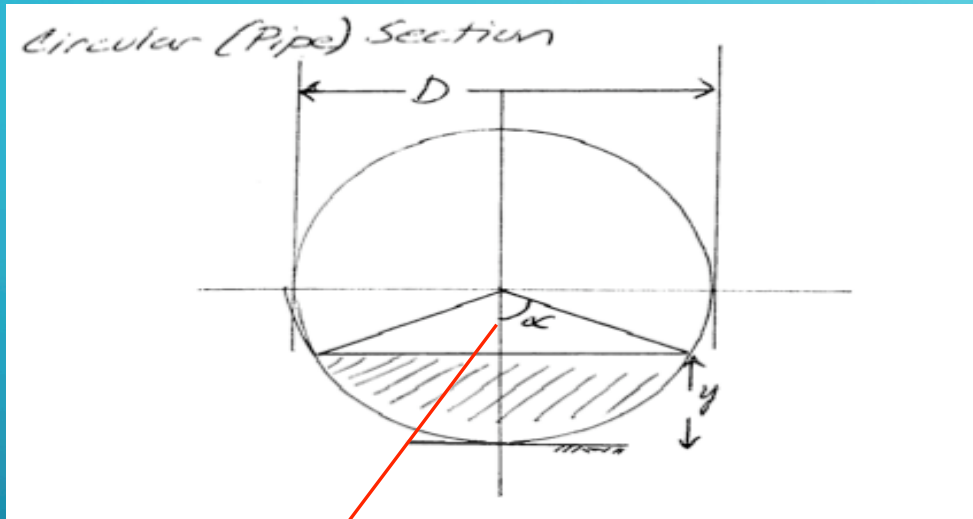

The most common sewer geometry  
(see pp 236-238 for similar development)

Depth-Topwidth:

$$T(y) = D \sin \alpha$$

Depth-Area:

$$A(y) = \frac{D^2}{4} (\alpha - \sin \alpha \cos \alpha)$$

Depth-Froude Number:

$$Fr^2(y) = \frac{Q^2 D \sin \alpha}{g \left( \frac{D^2}{4} (\alpha - \sin \alpha \cos \alpha) \right)^3}$$

$$\alpha(y) = \cos^{-1} \left( 1 - \frac{2y}{D} \right)$$

# VARIABLE STEP METHOD

- Compute WSE in circular pipeline on 0.001 slope.
  - Manning' s  $n=0.02$
  - $Q = 11$  cms
  - $D = 10$  meters
  - Downstream control depth is 8 meters.



# VARIABLE STEP METHOD

- Use spreadsheet, start at downstream control.

GVF Worksheet -- Variable Step Method														
Q(cms)	11													
n	0.02													
Section	Depth	Diame	Alpha	Area	Pw	Rh	Velocity	Energy	Friction S	Bottom	Delta x	Bottom	WSE	Station
→ 1	8	10	2.2143	67.4	22.14	3.04	0.163	8.001	2E-06	0.001	0	0	8	0
2	7.8	10	2.1652	65.7	21.65	3.04	0.167	7.801	3E-06	0.001	-200	0.2	8	-200
3	7.6	10	2.1176	64	21.18	3.02	0.172	7.602	3E-06	0.001	-200	0.401	8.001	-401

# VARIABLE STEP METHOD

- Compute Delta X, and move upstream to obtain station positions.

GVF Worksheet -- Variable Step Method														
Q(cms)	11													
n	0.02													
Section	Depth	Diame	Alpha	Area	Pw	Rh	Velocity	Energy	Friction S	Bottom	Delta x	Bottom	WSE	Station
1	8	10	2.2143	67.4	22.14	3.04	0.163	8.001	2E-06	0.001	0	0	8	0
2	7.8	10	2.1652	65.7	21.65	3.04	0.167	7.801	3E-06	0.001	-200	0.2	8	-200
3	7.6	10	2.1176	64	21.18	3.02	0.172	7.602	3E-06	0.001	-200	0.401	8.001	-401
4	7.4	10	2.0715	62.3	20.71	3.01	0.177	7.402	3E-06	0.001	-200	0.601	8.001	-601
5	7.2	10	2.0264	60.5	20.26	2.99	0.182	7.202	3E-06	0.001	-201	0.802	8.002	-802
6	7	10	1.9823	58.7	19.82	2.96	0.187	7.002	3E-06	0.001	-201	1.002	8.002	-1002
7	6.8	10	1.9391	56.9	19.39	2.93	0.193	6.802	4E-06	0.001	-201	1.203	8.003	-1203
8	6.6	10	1.8965	55	18.97	2.9	0.2	6.602	4E-06	0.001	-201	1.404	8.004	-1404
9	6.4	10	1.8546	53.1	18.55	2.86	0.207	6.402	4E-06	0.001	-201	1.604	8.004	-1604
10	6.2	10	1.8132	51.2	18.13	2.82	0.215	6.202	5E-06	0.001	-201	1.805	8.005	-1805
11	6	10	1.7722	49.2	17.72	2.78	0.224	6.003	5E-06	0.001	-201	2.006	8.006	-2006
12	5.8	10	1.7315	47.2	17.31	2.73	0.233	5.803	6E-06	0.001	-201	2.207	8.007	-2207
13	5.6	10	1.6911	45.3	16.91	2.68	0.243	5.603	7E-06	0.001	-201	2.408	8.008	-2408
14	5.4	10	1.6509	43.3	16.51	2.62	0.254	5.403	8E-06	0.001	-201	2.609	8.009	-2609
15	5.2	10	1.6108	41.3	16.11	2.56	0.267	5.204	9E-06	0.001	-201	2.81	8.01	-2810
16	5	10	1.5708	39.3	15.71	2.5	0.28	5.004	9E-06	0.001	-201	3.011	8.011	-3011

# VARIABLE STEP METHOD

- Use Station location, Bottom elevation and WSE to plot water surface profile.

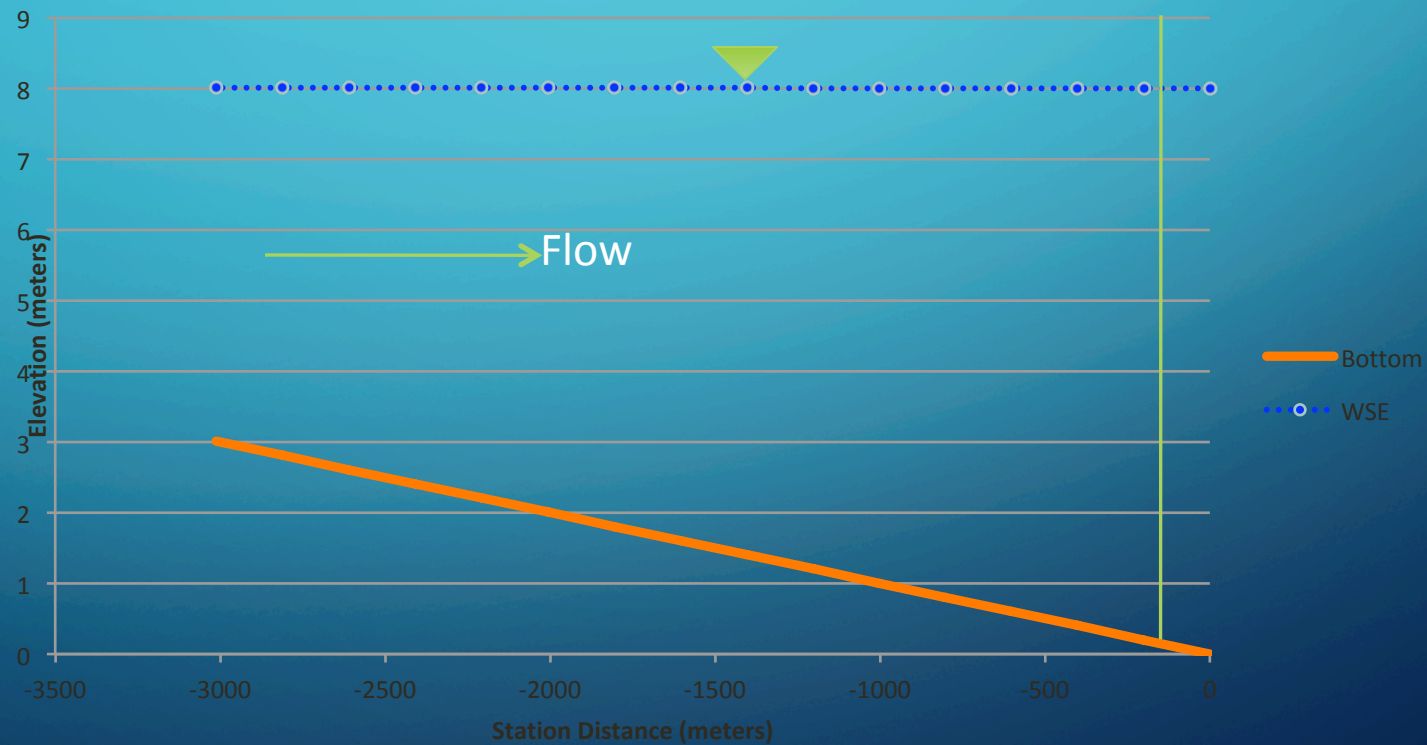



# NEXT TIME

- Introduction to SWMM