



CE 3372 WATER SYSTEMS DESIGN

PIPE HYDRAULICS PART 1 (FALL 2020)

FLOW CHARACTERISTICS

- Water moves from higher to lower energy
 - Path of least resistance
 - Head is energy per unit weight of a fluid
 - Pumps are used to add energy to move water to a higher elevation or over a barrier
- Gravity flow:
 - Change in elevation provides the required energy
- Pressure flow:
 - Change in pressure provides the required energy

FLOW RATE

- Flow of water creates friction/resistance; hence there is loss of energy along a flow path
- Mean section velocity is related to cross sectional flow area and volumetric discharge

$$\bar{V} = \frac{Q}{A}$$

CONTINUITY AT SECTIONS

4.2.1 Continuity between two cross-sections

The continuity equation between two cross-sections of a pipe as depicted in Figure 9 is

$$A_1V_1 = A_2V_2 \quad (2)$$

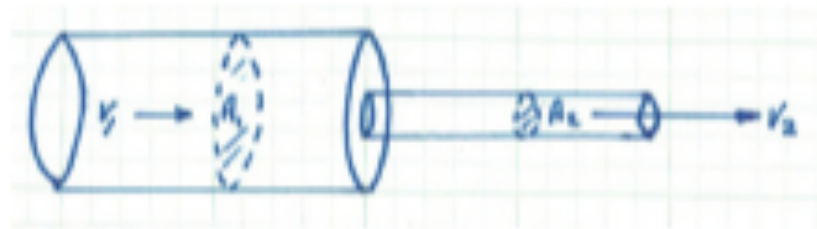

Figure 9: Continuity between cross-sections

CONTINUITY AT A JUNCTION

4.2.2 Continuity at a junction (node)

Junctions (nodes) are where two or more pipes join together. A three-pipe junction node

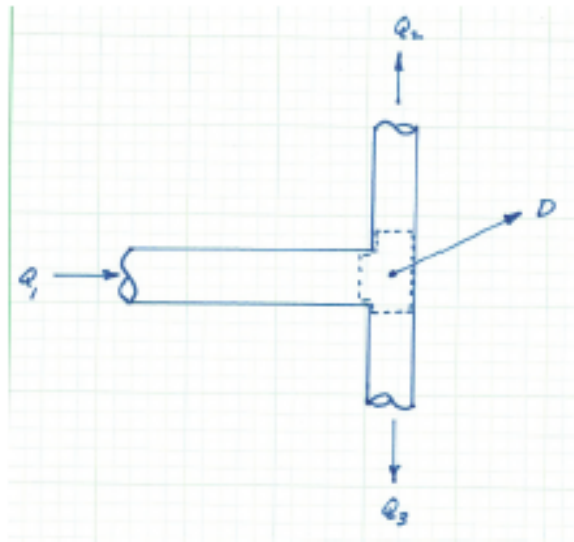

Figure 10: Continuity at a three-pipe junction with an external demand.

with constant external demand is shown in Figure 10. The continuity equation for the junction node is

$$Q_1 - Q_2 - Q_3 - D = 0 \quad (3)$$

ENERGY EQUATION

$$\frac{p_1}{\rho g} + \alpha_1 \frac{V_1^2}{2g} + z_1 + h_p = \frac{p_2}{\rho g} + \alpha_2 \frac{V_2^2}{2g} + z_2 + h_t + h_L$$

- The energy equation relates the total dynamic head at two points in a system, accounting for frictional losses and any added head from a pump.

h_L = head lost to friction

h_p = head supplied by a pump

h_t = head recovered by a turbine

ENERGY EQUATION

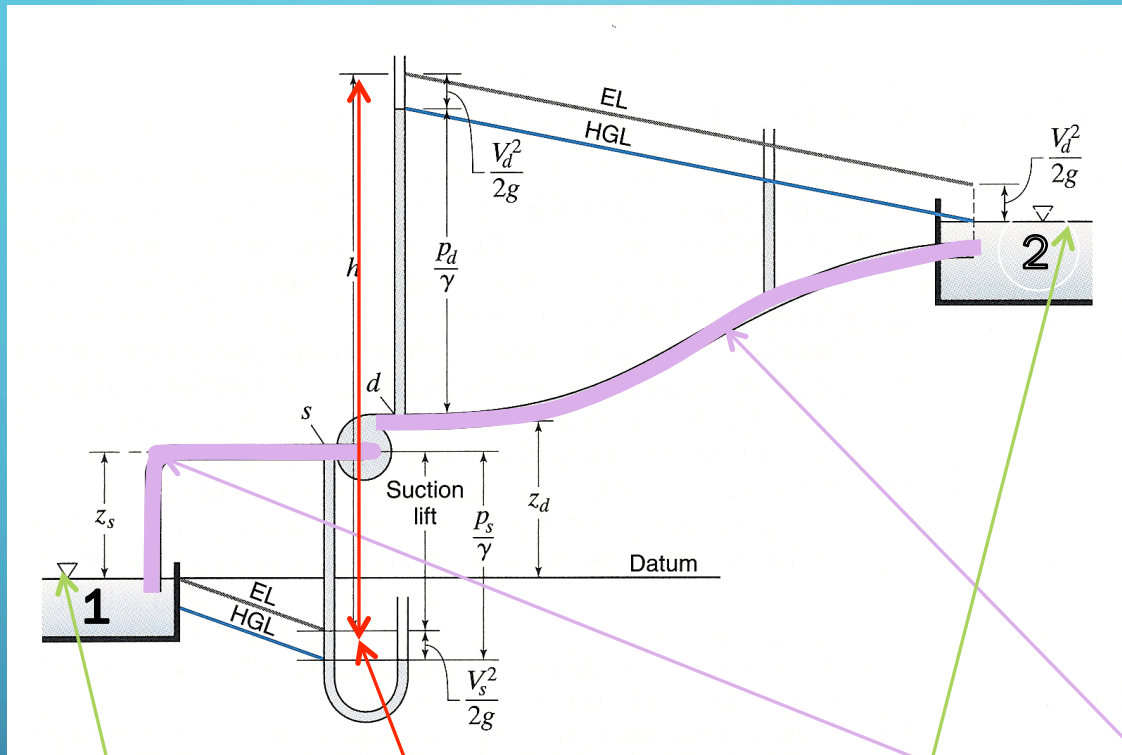

$$\frac{p_1}{\rho g} + \alpha_1 \frac{V_1^2}{2g} + z_1 + h_p = \frac{p_2}{\rho g} + \alpha_2 \frac{V_2^2}{2g} + z_2 + h_t + h_l$$

PIPE FLOW

- Energy loss is influenced by hydraulic and geometric properties
- Hydraulic properties:
 - Material (roughness)
 - Components (valves, bends, tees, ...)
 - Operating pressure
- Geometric properties:
 - Length
 - Cross section (shape and area)

HYDRAULIC GRADE LINE

- HGL is a line that represents the surface/profile of water flowing in partially full pipe

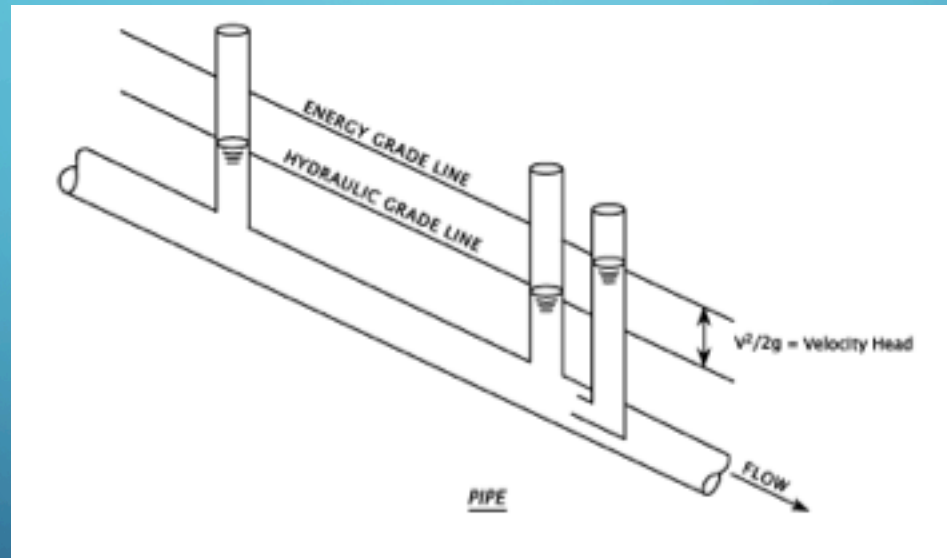

- If pipe is under pressure, flowing full the HGL rises to where a free surface would exist if there were a piezometer installed in the pipeline

ENERGY GRADE LINE

- EGL is a line that represents the elevation of energy head of water flowing in a conduit. It is the sum of the elevation, pressure, and velocity head at a location

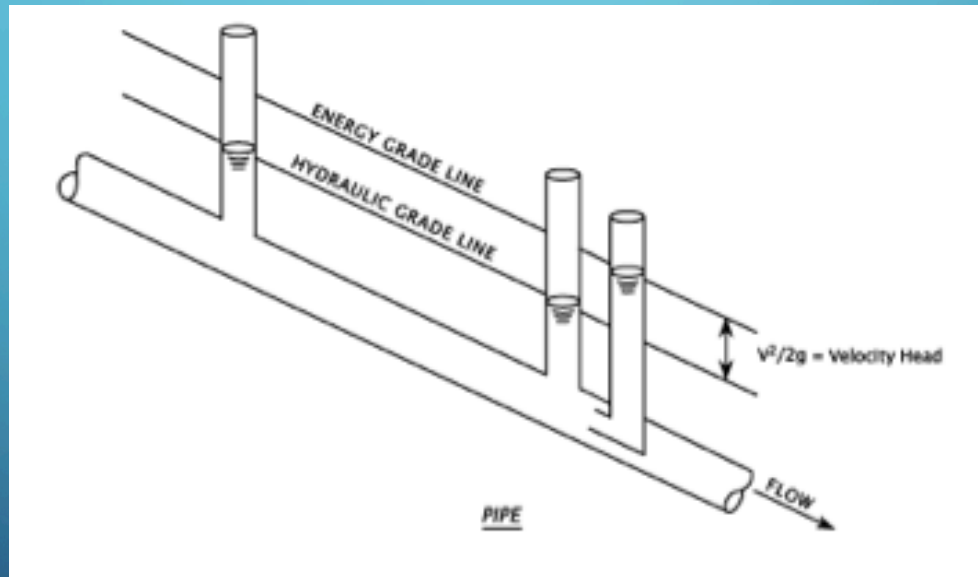

- Drawn above HGL at a distance equal to the velocity head

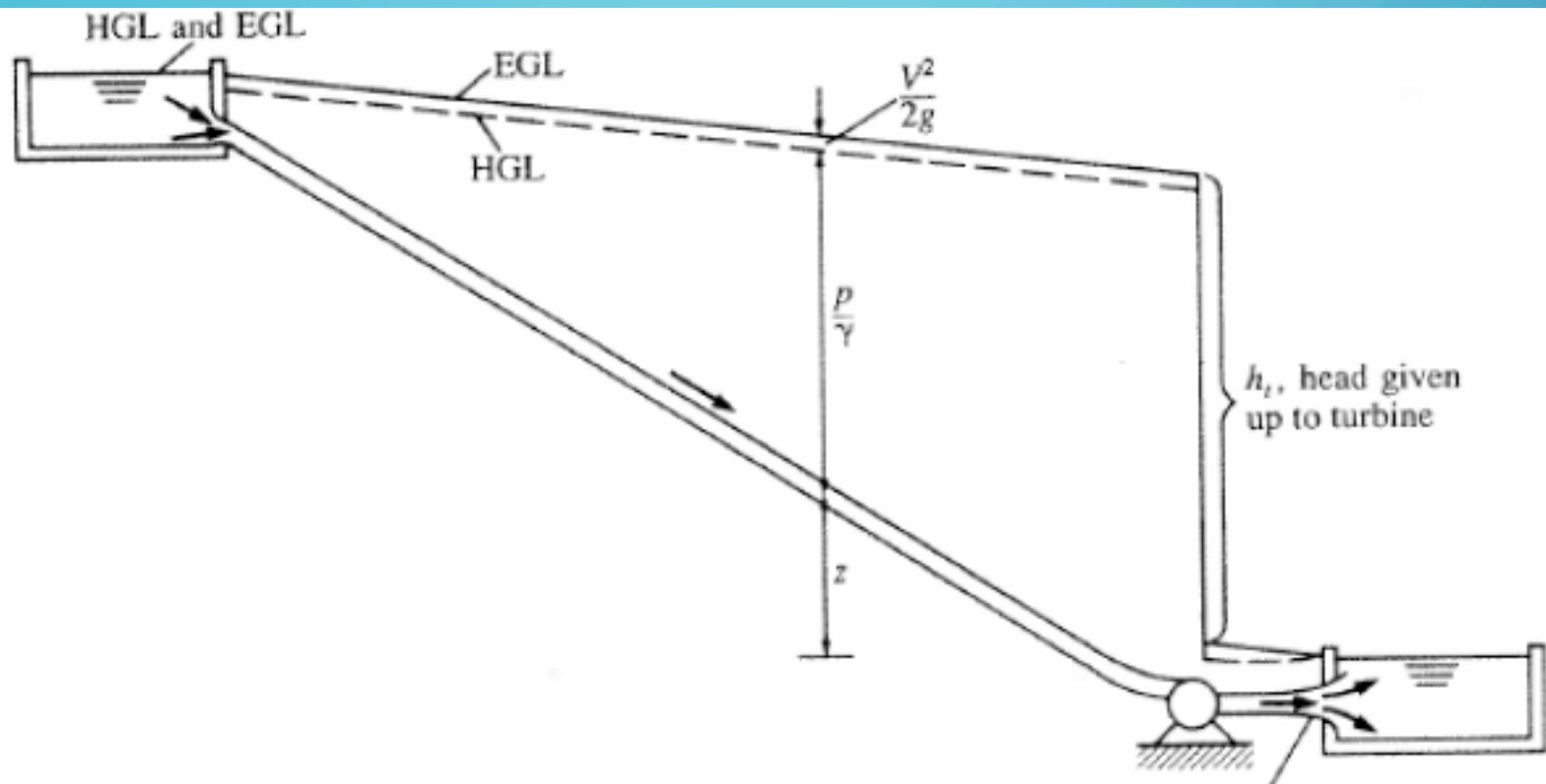

Gradual expansion of conduit allows velocity head to be converted to pressure head with much smaller h_L at the outlet; hence, the HGL approaches the EGL.

Figure 6: HGL and EGL and energy loss in a turbine system.