

H7

Friction Loss in a Pipe

User Guide

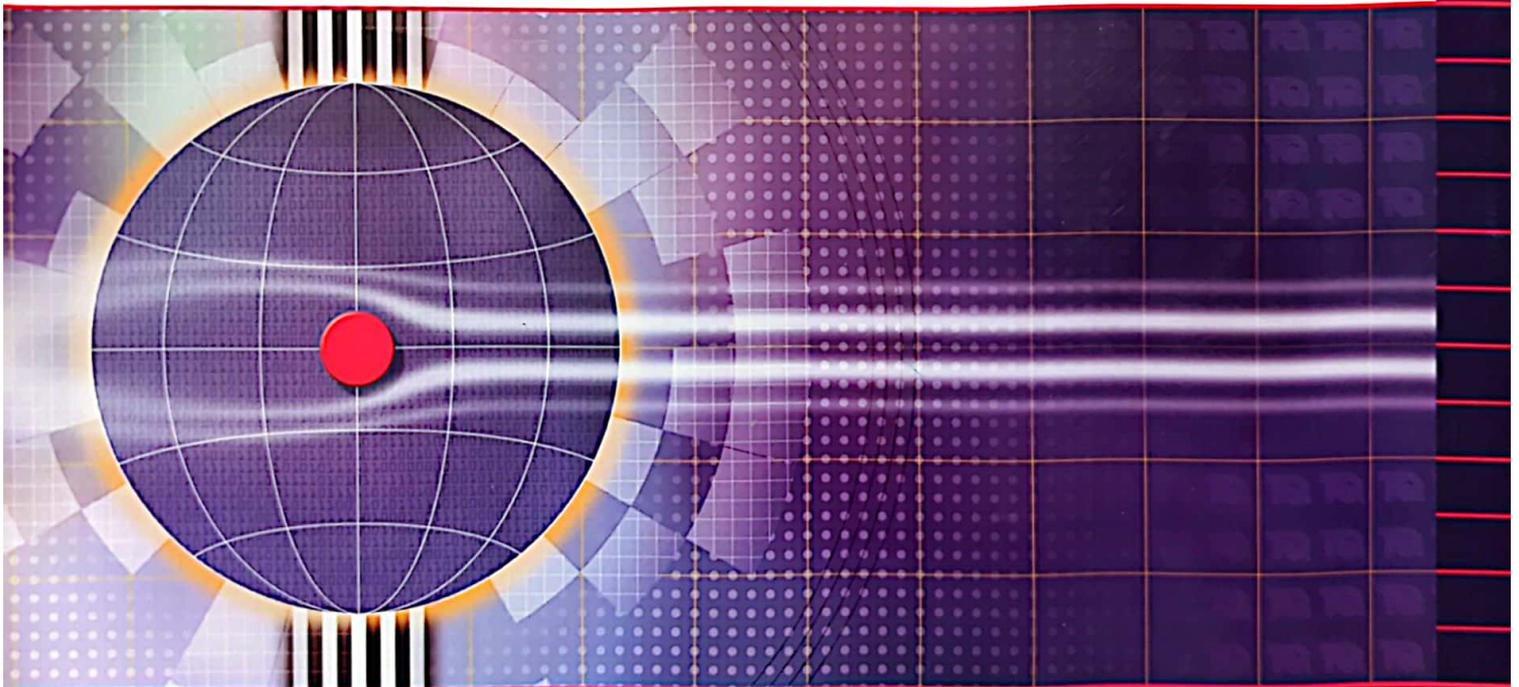

Contents

Introduction	1
Description	3
Technical Details	5
Noise Levels	5
Installation and Assembly	7
Theory	13
Notation	13
Unit Conversions	13
Water Density (ρ) and Viscosity (μ or ν)	14
Frictional Loss and the Hydraulic Gradient (i)	15
Reynolds Number and Flow	15
Derivation of Poiseuille's Equation - Laminar Flow	17
Derivation of Darcy's Equation - Turbulent Flow	19
To Find Hydraulic Gradient (i)	21
To Find Flow Velocity (u)	21
Experiments	23
Useful Notes	23
Procedure 1 - Lower Flow Rates	25
Procedure 2 - Higher Flow Rates	27
Results Analysis	29
Typical Results	31
Maintenance, Spare Parts and Customer Care	35
Maintenance	35
Spare Parts	35
Customer Care	36

H7

Friction Loss in a Pipe

User Guide

Introduction



Figure 1 H7 Friction Loss in a Pipe Apparatus (Shown without the Header Tank)

The TecEquipment Friction Loss in a Pipe apparatus (H7) fits onto either of TecEquipment's Hydraulic Benches. It works over a range of flow to allow experiments that find friction loss in a small bore horizontal pipe and compare theory with actual results for laminar and turbulent flow. The experiments also show the flow transition point and the critical Reynolds number.

Description

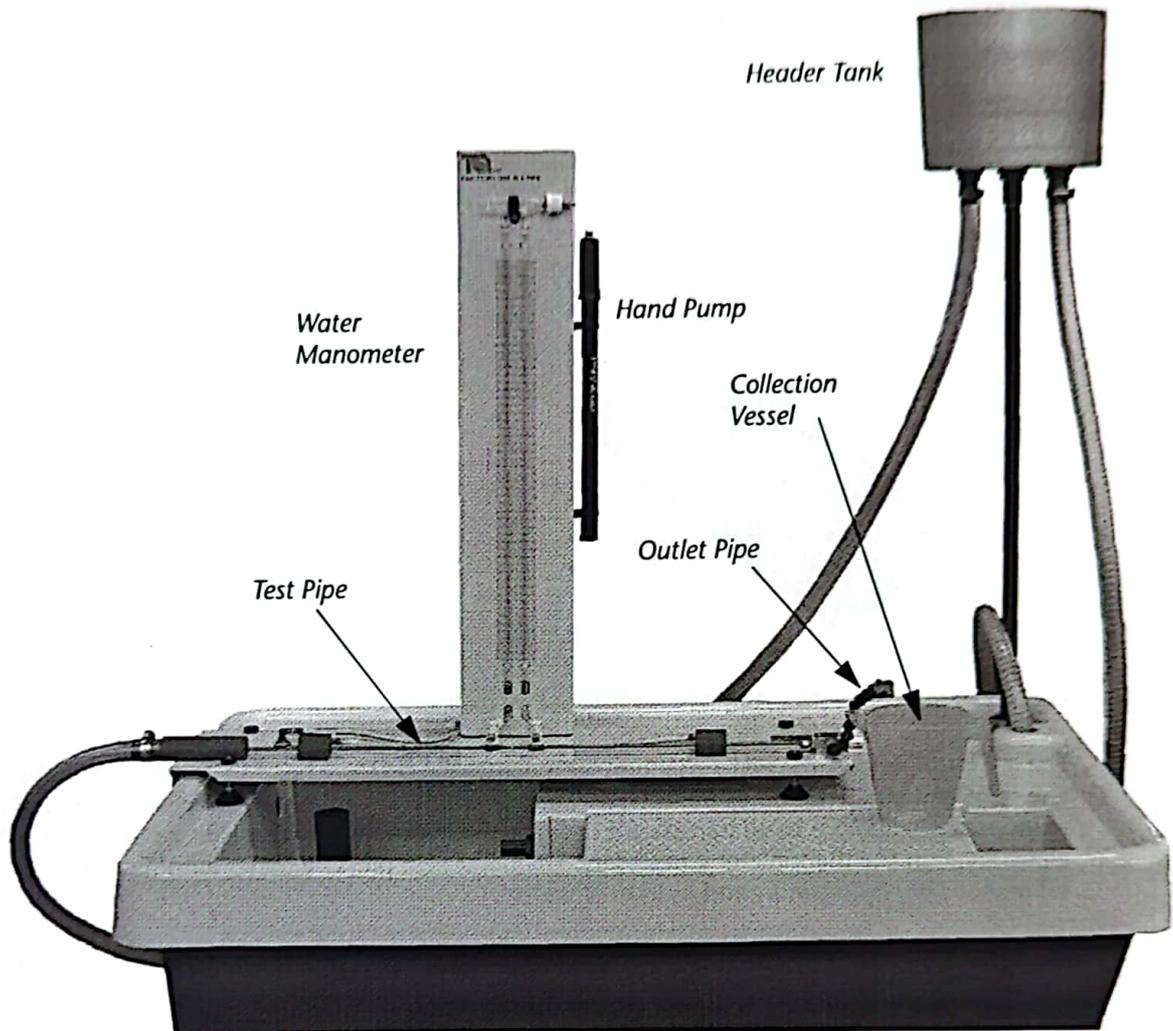

Figure 2 Main Parts

Figure 2 shows the main parts of the equipment - shown fitted to a TecEquipment Hydraulic Bench (not supplied).

A base plate holds a horizontal narrow-bore test pipe. Water enters the test pipe from the left hand side or 'upstream' end and leaves at the opposite end or 'downstream' end. A precision needle valve at the downstream end allows accurate control of the flow through the pipe. The valve is downstream rather than upstream so that it cannot disturb the flow quality through the pipe. The pipe entrance has tapered chambers to gradually reduce the flow diameter to match the pipe. For reference, TecEquipment supply a small sample of the test pipe with the equipment.

The test pipe has two pressure tappings. One is near to the upstream end at approximately 45 tube diameters away from the pipe entrance. The other is near to the downstream end at approximately 40 tube diameters away from the pipe exit. These distances are important to prevent the results from being affected by disturbances near the entrance and exit of the pipe.

The tappings connect to sockets on the baseplate, so the user can choose whether to measure the pressure using the inverted U-tube water manometer or a hand-held pressure meter. For lower flow rates

you connect the manometer, which reads the differential pressure directly in millimetres of water. For higher flow rates you connect the hand-held differential pressure meter.



The hand-held meter works to very low pressure levels and gives good results for the higher pressures in the turbulent flow experiments, but the water manometer works better at the much lower pressures during laminar flow.



Figure 3 Hand Held Pressure Meter

The left hand limb of the water manometer measure the pressure head (h_1) upstream of the test pipe. The right hand limb measures the pressure head (h_2) downstream of the test pipe. The top of the water manometer includes a small transparent chamber with an air valve. This allows students to offset the water levels in the manometer if necessary. The hand-held pressure meter automatically shows the difference (Δh) between h_1 and h_2 in m of water.

A short bleed pipe allows the user to bleed trapped air from the pressure pipes before connecting the manometer or hand held meter.

The flow through the pipe is too small to measure using the hydraulic bench measurement systems, so TecQuipment supply the equipment with a graduated container to measure flow rate from a flexible outlet at the downstream end. TecQuipment's Hydraulic Benches include a stopwatch to help you calculate water flow rate.

The unit fits onto either a H1 or H1D bench (not supplied), which also works as the water supply. The equipment also includes a Header Tank to provide a uniform, constant head (approximately 1 m head) flow for the lower flow rates, while the pump in the hydraulic bench provides a more direct flow for the higher flow rates. The Header Tank fits into the holes in the corners of the lid of the hydraulic benches.

Technical Details

Item	Details
Dimensions and weight (assembled)	Main Unit: 1000 mm long, 860 mm high and 250 mm front to back and 5 kg. Header Tank: 400 mm x 250 mm outside diameter tank with 800 mm overflow/support pipe, combined weight of 5 kg. Hand-held meter 0.5 kg Total weight of all items approximately 10.5 kg.
Test Pipe	Internal Diameter (nominal): 3.0 mm Nominal Cross Sectional Area: 7.06 mm ² Distance between tappings: 524 mm
Water manometer range	0 to 530 mm water
Hand-held meter range	0 to 20.43 m of water or 0.0 to 199.9 kPa

Noise Levels

The noise levels recorded at this apparatus are lower than 70 dB (A).

Installation and Assembly

The terms **left**, **right**, **front** and **rear** of the apparatus refer to the operators' position, facing the unit.



- A wax coating may have been applied to parts of this apparatus to prevent corrosion during transport. Remove the wax coating by using paraffin or white spirit, applied with either a soft brush or a cloth.
- Follow any regulations that affect the installation, operation and maintenance of this apparatus in the country where it is to be used.

TecQuipment supply the apparatus disassembled for transport. To reassemble:

1. Use the fixings supplied to fit the back panel to the base board.
2. Clip the hand pump to the side of the back panel.
3. Put the assembled equipment onto the top of a Hydraulic Bench and use its adjustable feet to make it level.

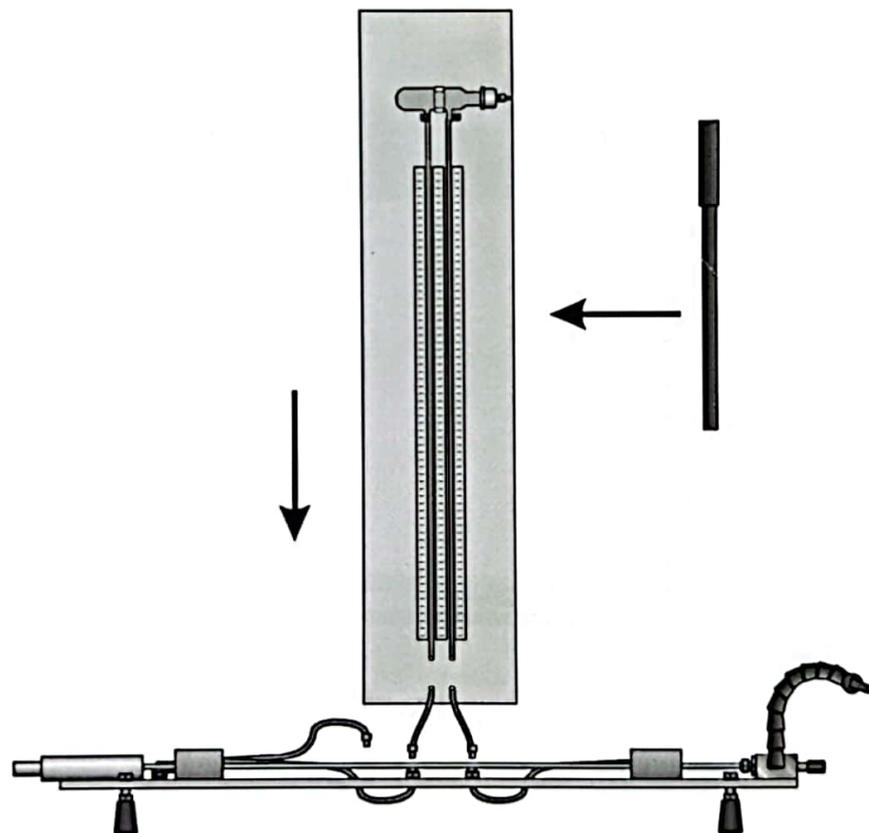

Figure 4 Fit the Back Panel to the Base and Connect the Tubes Correctly

4. Fit the two parts of the Header Tank connection into one of the holes of the Hydraulic Bench - preferably nearest the flow control valve of the Hydraulic Bench. Connect the short piece of pipe (supplied) to the lowest part. See Figure 5. Assemble and connect the Header Tank to the connection as shown in Figures 5 and 6. Its overflow pipe is also the support for the Header Tank.

5. Figures 7 and 8 show how you connect the pipes through the Header Tank when you do the lower flow and higher flow parts of the experiments.

Connection on top of Hydraulic Bench

Connection underneath top of Hydraulic Bench

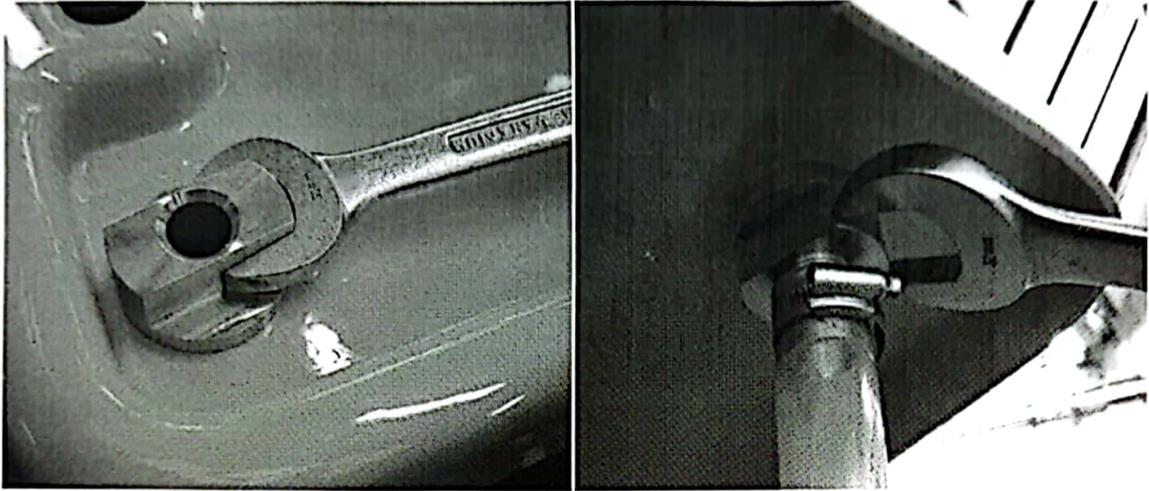

Figure 5 Fit the Header Tank Overflow Pipe Connector to the Hydraulic Bench Top

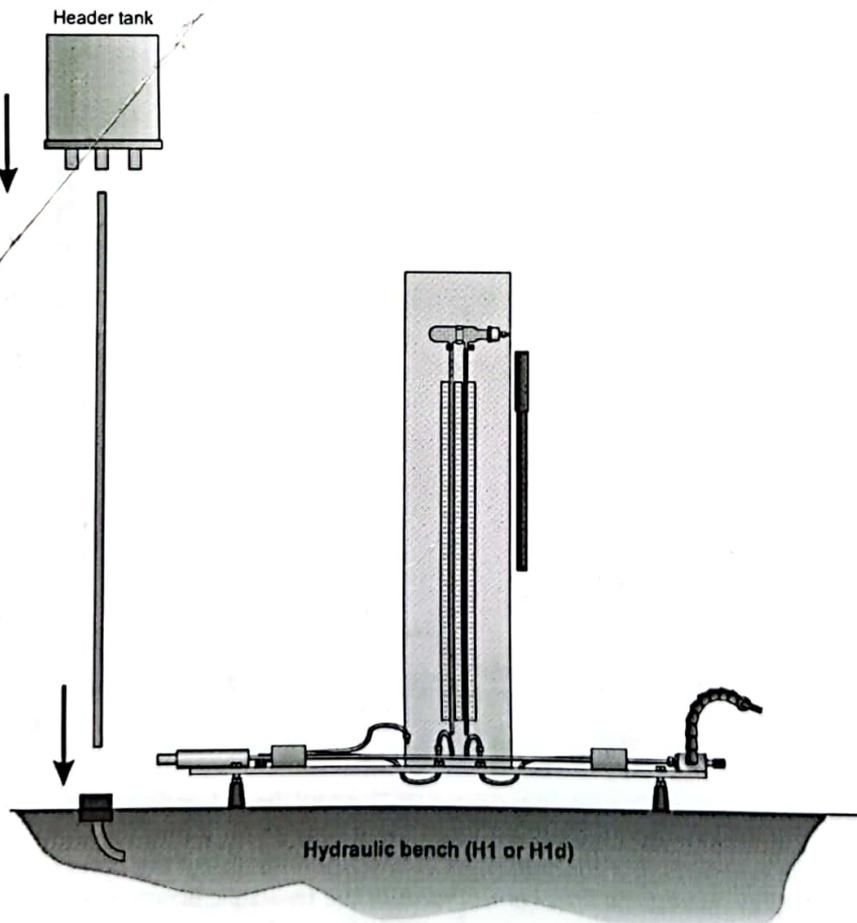

Figure 6 Fit the Header Tank and Its Overflow/Support Pipe to the Hydraulic Bench

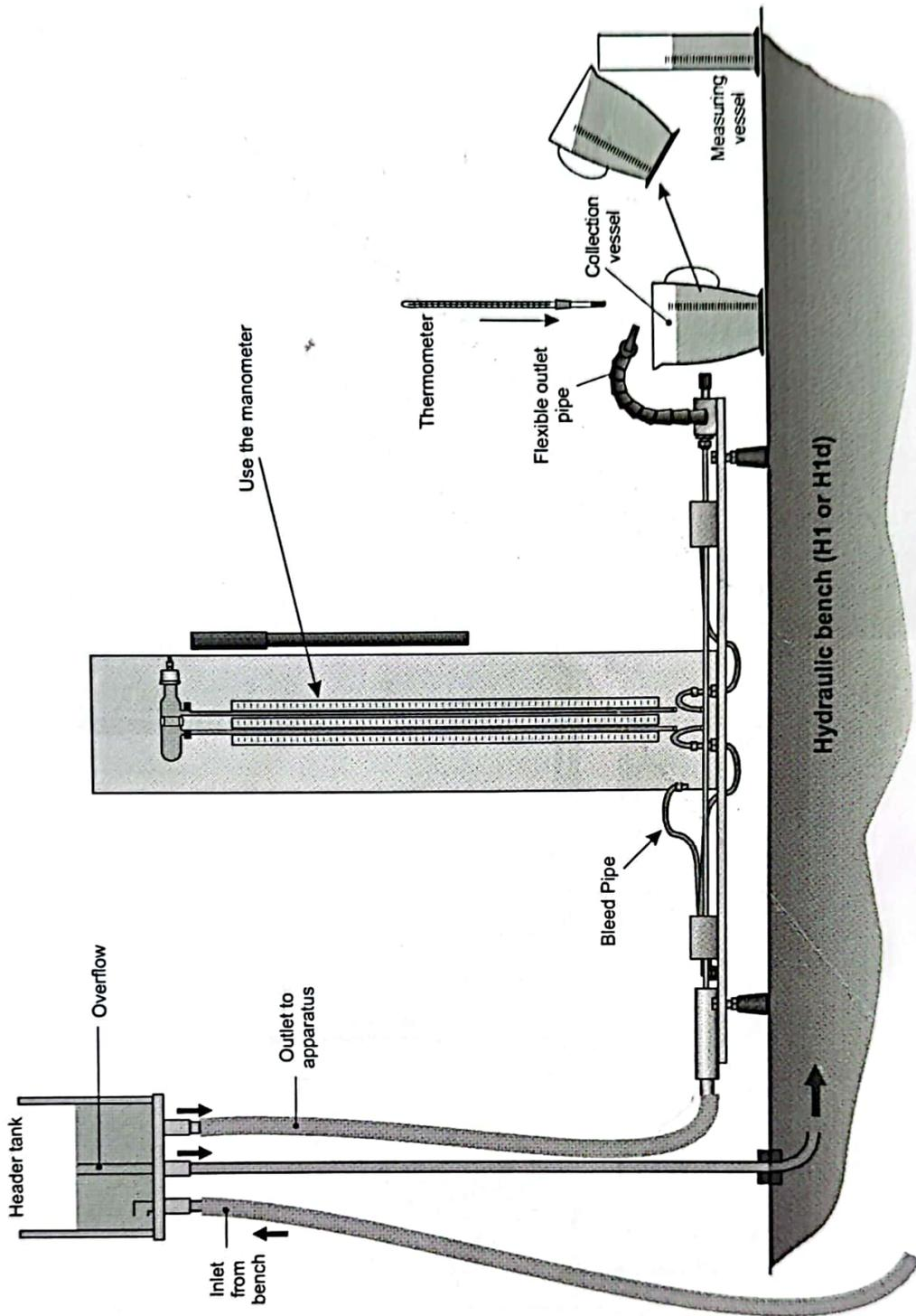

Figure 7 Connections for the Lower Flow Experiment

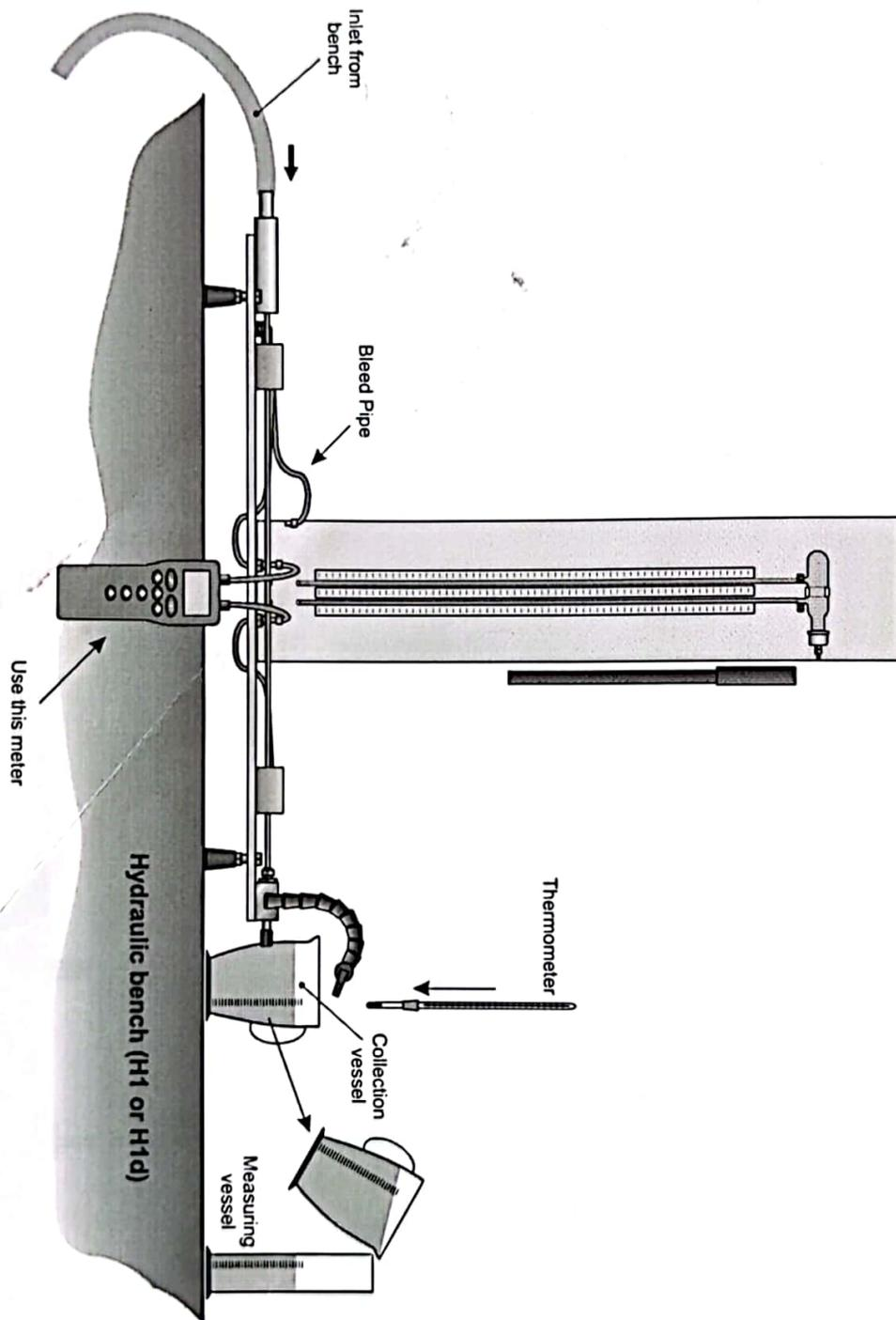

Figure 8 Connections for the Higher Flow Experiment

6. Read the manufacturers instruction leaflet and fit batteries to the pressure meter.



Figure 9 Fit Batteries to the Pressure Meter

Theory

Notation

Symbol	Meaning	Units
Re	Reynolds Number of the motion	-
ρ	Density of the fluid	kg.m^{-3}
u	Velocity of flow	m.s^{-1}
i	Hydraulic Gradient	-
D	Diameter of the pipe	m
μ	Coefficient of absolute or dynamic viscosity of the fluid	Pa.s
h_1	Upstream Head	mm of water
h_2	Downstream Head	mm of water
Δh	Head Differential (h_1-h_2)	m of water
l	Distance between pressure tapings	m (or mm where stated)
Q	Flow or discharge	$\text{m}^3.\text{s}^{-1}$ (or L/s where stated)
A	Test Pipe cross-sectional area	m^2
a	A distance across the pipe	m
r	Radius of Test Pipe	m
g	Acceleration due to gravity	m.s^{-2}
ν	μ/ρ or coefficient of kinematic viscosity of the fluid	$\text{m}^2.\text{s}^{-1}$
f	Friction loss	

Table 1 Notation

Unit Conversions

Dynamic Viscosity: $1 \text{ N.s/m}^2 = 1 \text{ Pa.s} = 1000 \text{ mPa.s} = 1 \text{ kg/ms}$

Kinematic Viscosity: $1 \text{ m}^2/\text{s} = 1 \times 10^4 \text{ cm}^2/\text{s} = 1 \times 10^4 \text{ stokes} = 1 \times 10^6 \text{ centistokes}$

Volume Flow: $1 \text{ m}^3/\text{s} = 1000 \text{ L/s}$

Water Density (ρ) and Viscosity (μ or ν)

Density is a measure of the mass per unit volume of water. Where the water's mass increases even though its volume remains the same, then it has a higher density. The density of water changes with temperature. It is most dense ($\sim 1000 \text{ kg/m}^3$) at around 4°C and decreases with increasing and decreasing temperature.

Viscosity is a measure of a fluid's resistance to flow. Low viscosity fluids (like water) flow easily. High viscosity fluids (like honey or treacle) flow less easily.

There are two related measures of viscosity:

Dynamic or Absolute Viscosity (μ)

This value is often called simple viscosity. It is the basic measure of viscosity in Pa.s (Pascals per second).

Kinematic Viscosity (ν)

This is the ratio of dynamic viscosity to density, or 'resistive flow under the influence of gravity'. It is measured in $\text{m}^2.\text{s}$ (metres squared per second) or sometimes in Centistokes (cSt).

$$\nu = \frac{\mu}{\rho}$$

Table 2 shows how the dynamic viscosity (mPa.s or $\text{Pa.s} \times 10^{-3}$) of water changes with temperature.

$\theta^\circ\text{C}$	0	1	2	3	4	5	6	7	8	9
10	1.307	1.271	1.236	1.202	1.170	1.140	1.110	1.082	1.055	1.029
20	1.004	0.980	0.957	0.935	0.914	0.893	0.873	0.854	0.836	0.818
30	0.801	0.784	0.769	0.753	0.738	0.724	0.710	0.696	0.683	0.658

Table 2 Dynamic Viscosity of Water (mPa.s)

Alternatively, you can calculate it from:

$$\mu = \frac{i}{u} \cdot \frac{\rho g D^2}{32} \quad (1)$$

Frictional Loss and the Hydraulic Gradient (i)

As fluid flows along a pipe, it experiences frictional resistance that gives a loss of energy, or 'total head' of the fluid. Figure 10 shows this in a simple case; the difference in levels between piezometers A and B are the total head loss, h , in the length of pipe, l . In hydraulic engineering the rate of loss of total head along a pipe, dh/dl , is 'hydraulic gradient', denoted by the symbol i , so that:

$$\frac{dh}{dl} = i \quad (2)$$

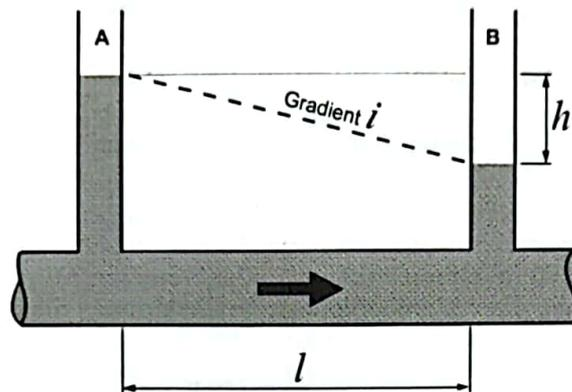

Figure 10 Hydraulic Gradient

Reynolds Number and Flow

In 1883, Osborne Reynolds experimented with flow in pipes by adding a filament of dye into the flow of water along a glass pipe. He noticed two different types of motion:

1. At low velocities the filament appeared as a straight line, which passed down the whole length of the tube, indicating **laminar flow**.
2. At higher velocities, the filament, after passing a little way along the tube, suddenly mixed with the surrounding water, indicating that the motion had now become **turbulent**.

Experiments with smooth, circular cross-section pipes of different diameters and with water at different temperatures, led Reynolds to create an equation that helps predicts whether the flow is laminar or turbulent:

$$Re = \frac{\rho u D}{\mu} \quad (3)$$

or as shown in some textbooks:

$$Re = \frac{uD}{\nu} \quad (\text{as } \nu = \mu/\rho) \quad (4)$$

This motion is laminar or turbulent according to whether the value of Re is less than or greater than a certain **critical value**. However, this critical value also depends on how you do the experiment.

- If you gradually **increase** the flow, the change from laminar to turbulent flow and therefore the critical value of Re depends on how carefully you smooth out disturbances in the supply and along the pipe.
- If you gradually **decrease** the flow, transition from turbulent to laminar flow is unaffected by those disturbances. When the flow is below the transition point, it quickly becomes laminar downstream of any disturbance, no matter how severe.
Under these circumstances, the value of Re is about 2000.

As a general guide, for smooth pipes:

- Laminar Flow $Re < 2000$
- Transitional Flow $Re = 2000$ to 4000
- Turbulent Flow $Re > 4000$

Different laws of resistance apply to laminar and to turbulent flow. For a given fluid flowing along a given pipe of diameter D , experiments show that:

For laminar motion

Hydraulic gradient is directly proportional to flow velocity:

$$i \propto u \tag{5}$$

or alternatively:

$$i = ku$$

Poiseuille's equation gives the terms of the constant, so that:

$$i = \frac{32\mu}{\rho g D^2} \times u \text{ or } i = \frac{32\mu u}{\rho g D^2} \tag{6}$$

For turbulent motion

Hydraulic gradient is proportional to flow to a given power (n):

$$i \propto u^n \tag{7}$$

Where n is an index between 1.7 and 2.0 - determined by the value of Re and on the roughness of the wall of the pipe.

There is no simple general equation for turbulent flow, so engineers normally use Darcy's equation:

$$i = \frac{4fu^2}{D2g} \tag{8}$$

where f is an experimentally-determined 'friction factor' which varies with Re and pipe roughness.

Derivation of Poiseuille's Equation - Laminar Flow

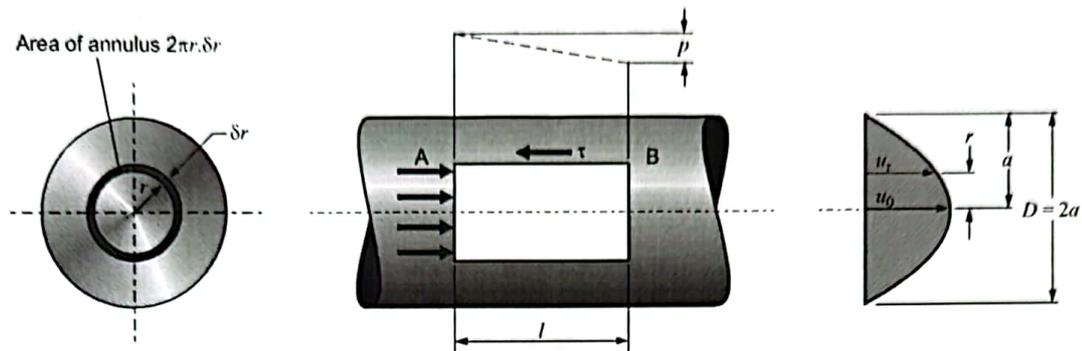

Figure 11 Derivation of Poiseuille's equation

To derive Poiseuille's equation, which applies to laminar flow along a tube, consider the motion indicated in Figure 11. Over each cross-section of the tube, the piezometric pressure is constant, and this pressure falls continuously along the tube. Suppose that between cross-sections A and B, separated by length l of the tube, the fall in pressure is p . Then the force exerted by this pressure difference on the ends of a cylinder having radius r , and its axis on the centre line of the tube, is $p\pi r^2$. Over any cross-section of the tube, the velocity varies with radius, having a maximum value of u_0 at the centre and falling to zero at the wall; let the velocity at radius r in any cross-section be denoted by u_r . Then the shear stress τ , in the direction shown in Figure 11, due to viscous action on the curved surface of the cylinder, is given by:

$$\tau = \mu \frac{du_r}{dr} \quad (9)$$

(Note that $\frac{du_r}{dr}$ is negative so that the stress acts in the direction shown in Figure 11.)

The force on the cylinder due to this stress is $\mu \frac{du_r}{dr} 2\pi r l$. Since the fluid is in steady motion under the action of the sum of pressure and viscous forces:

$$p\pi r^2 + \mu \frac{du_r}{dr} 2\pi r l = 0$$

Therefore:

$$\frac{du_r}{dr} = -\frac{pr}{2l\mu} \quad (10)$$

$u_r = 0$ when $r = a$

$$u_r = \frac{p}{4l\mu} (a^2 - r^2) \quad (11)$$

This result shows a parabolic velocity distribution across a section, as shown on Figure 11, and that the velocity on the centre line, given by putting $r = 0$ in Equation (11), is:

$$u_0 = \frac{pa^2}{4l\mu} \quad (12)$$

The discharge rate, Q , may now be calculated. The flow rate, δQ , through an annulus of radius r and width δr is:

$$\delta Q = u_r 2\pi r \delta r$$

Inserting u_r from Equation (11) and integrating:

$$Q = \frac{p}{4l\mu} 2\pi \int_0^a (a^2 r - r^3) dr$$

Therefore,

$$Q = \frac{p\pi a^4}{8l\mu} \quad (13)$$

Now the mean velocity u over the cross-section is, by definition, given by:

$$Q = u\pi a^2 \quad (14)$$

and eliminating Q between Equations (13) and (14) gives:

$$u = \frac{pa^2}{8l\mu} = \frac{pD^2}{32l\mu} \quad (15)$$

which may be written in the form exactly as Equation 6 by use of the substitutions, $\rho gh = p$ and $i = \frac{h}{l}$.

Derivation of Darcy's Equation - Turbulent Flow

With a turbulent flow, the Poiseuille's derivation is not applicable because of the continuous mixing process in the flow. Across the curved surface of the cylinder having radius r in Figure 11, this mixing creates a continuous unsteady and random flow into and out of the cylinder, so that the apparent shear stress on this surface is greater than the value given in Equation 9. Because of the mixing, the distribution of velocity over a cross-section is more uniform than the parabolic shape deduced for laminar flow, shown in Figure 11.

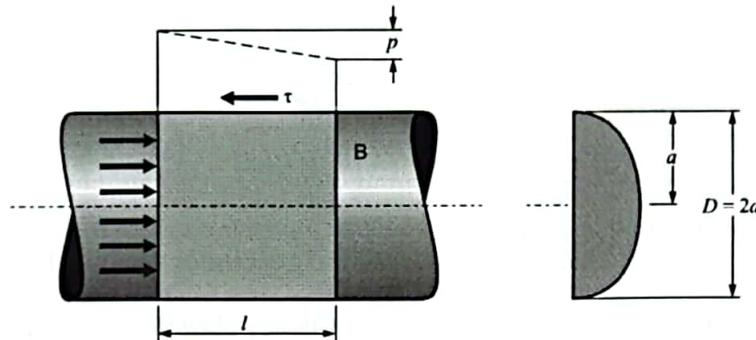

Figure 12 Derivation of Darcy's equation

Although it is not possible to perform a complete analysis for turbulent flow, a useful result may be obtained by considering the whole cross-section as shown in Figure 12. It is reasonable to suppose that the shear stress τ_0 on the wall of the tube will depend on the mean velocity u . Let us assume for the present that:

$$\tau_0 = f \sqrt{2} \rho u^2 \quad (16)$$

where:

$\sqrt{2} \rho u^2$ = Dynamic pressure corresponding to the mean velocity u
 f = Friction factor (not necessarily constant)

Friction factor f is dimensionless, since τ_0 and $\sqrt{2} \rho u^2$ each have dimensions of force per unit area. The force on a cylinder of length l due to this stress is $f \cdot \sqrt{2} \rho u^2 \cdot 2\pi a l$ and the force due to the fall in pressure is $p\pi a^2$, so that:

$$p\pi a^2 = f \sqrt{2} \rho u^2 \cdot 2\pi a l$$

Substituting:

$$\rho g h = p, \quad \frac{h}{l} = i \quad \text{and} \quad a = \frac{D}{2}$$

which leads to the result:

$$i = \frac{4f}{D} \cdot \frac{u^2}{2g} \quad (17)$$

which is a form of Darcy's equation.

Friction Factor (f) and Blasius

Friction factor is a variable that you can only find from experiment. It is a measure of the friction in a certain flow condition and varies with pipe wall roughness and the Reynolds number.

NOTE  Do not confuse friction factor with friction loss - they are two different terms.

By rearrangement of Darcy's Equation (17):

$$f = \frac{iD}{(4u^2)/(2g)} \quad (18)$$

- At any given value of Re , f increases with increasing surface roughness.
- For any given surface roughness, f generally decreases slowly with increasing Re .

This means that if Re increases, caused by an increase in flow (u) along a given pipe, f will decrease slowly, so that the product $f u^2$ will increase less than u^2 . This means that over a fairly wide range, it is often possible to represent the variation of i with u by the approximation:

$$i = k u^n \quad (19)$$

where k and n are constants for a given fluid flowing along a given pipe, n having a value between 1.7 and 2.0.

A German fluid dynamics engineer - Paul Blasius found an alternative equation for friction factor that applies to turbulent flow, when you already have the Reynolds number:

$$f = 0.079 Re^{-0.25} \quad (20)$$

However, this equation will only work for a range of Reynolds numbers, where the flow is termed as **smooth turbulent flow**, or the lower regions of turbulent flow.

To Find Hydraulic Gradient (i)

1. For water manometer:

$$i = \frac{(h_1 - h_2)}{l} \text{ (all units in millimetres or all units in metres)}$$

2. For the pressure meter:

$$i = \frac{\Delta h}{l} \text{ (all units in millimetres or all units in metres)}$$

To Find Flow Velocity (u)

$$u = \frac{Q}{A} \text{ (all units in metres and seconds)}$$

Experiments

Useful Notes

Two People

TecEquipment recommend that at least two people do to the experiments. One person to take readings and the other to adjust the flow rates.

Splashes of Water

This apparatus uses water and may splash some onto the top of the Hydraulic Bench. Be prepared for small splashes of water.

Flow Rate and Water Temperature

To measure flow rate, you must bend the flexible outlet pipe into a shape so that you can put the container (supplied) underneath the end of the outlet pipe to catch the water and measure its temperature.



Do not readjust the outlet pipe during your experiments, or you will affect the flow and your results.

You use a stopwatch to measure the time you take to collect a certain volume of water.

Good Connections

TecEquipment's Hydraulic Benches produce reasonably high flow and pressure, so make sure that your pipe connections are good, especially when you do the higher flow procedure.

Procedure 1 - Lower Flow Rates

1. Create a blank results table similar to Table 3.
2. Set up the equipment as described in **Installation and Assembly**, with the output of the Hydraulic Bench connected to the header tank, and the Header Tank connected as the supply to the inlet of the Friction Loss in a Pipe.
3. Switch on the Hydraulic Bench pump and carefully adjust its supply valve until there is a steady flow down the supply tank overflow pipe, without overflowing the Header Tank.
4. Partly open the needle valve on the downstream end of the test pipe and allow water to flow through the test pipe.
5. Use the bleed pipe with the bleed connection to bleed trapped air from the pressure tapping pipework (both pipes). The self-sealing sockets of the pressure tapplings will now hold the water in their pipes.

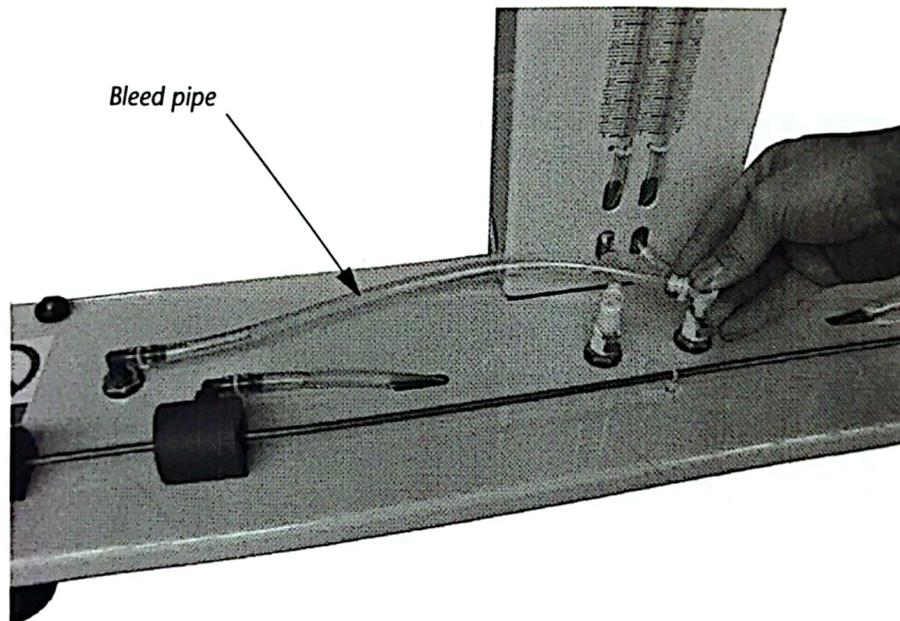

Figure 13 Use the Bleed Pipe to Bleed air from the Pressure Tappings

6. Connect the water manometer and check that its pipes start to fill with water and any trapped air moves up to the top of the manometer (you may need to gently tap the pipes to help move the trapped air).
7. Adjust the flexible outlet pipe at the downstream end of the test pipe so that it will pour into the container supplied.
8. Shut the needle valve and check that the levels in the water manometer settle to the same value. If they do not, check that flow has stopped, and that all trapped air bubbles have been cleared from their pipes.
9. If necessary, use the hand pump to add some air to the air valve and chamber at the top of the water manometer, or press the air valve slightly to release air so the water levels are near the middle of the scale range (at around 260 mm).

10. Carefully open and adjust the needle valve to give a differential head ($h_1 - h_2$) of around 450 mm on the water manometer. Record these values.
11. Use the collection and measuring vessels supplied, and a stopwatch (not supplied) to time the collection of a suitable quantity of water from the outlet pipe (for example 500 mL). Measure and record the temperature of the water that you collect.

Use the needle valve to reduce the differential in roughly 30 mm steps, to give at least ten sets of results. Stop taking results at around 30 mm differential. At each step, record the differential, the flow rate and the water temperature.

Procedure 2 - Higher Flow Rates

1. Create a blank results table similar to Table 3.
2. Set up the equipment as described in **Installation and Assembly**, with the output of the Hydraulic Bench connected directly to the inlet of the Friction Loss in a Pipe.
3. Switch on the Hydraulic Bench pump and half open its supply valve.
4. Fully open the needle valve on the downstream end of the test pipe and allow water to flow through the test pipe.
5. As in procedure 1, use the bleed pipe with the bleed connection to bleed trapped air from the pressure tapping pipework (both pipes). The self-sealing sockets of the pressure tapplings will now hold the water in their pipes.
6. Before you connect the hand-held pressure meter, set its display to zero and to show a value in mH_2O .
7. Connect the hand-held pressure meter.

NOTE



For best results, hold the hand-held meter level. This prevents the meter from measuring any small amounts of water trapped in its pipes.

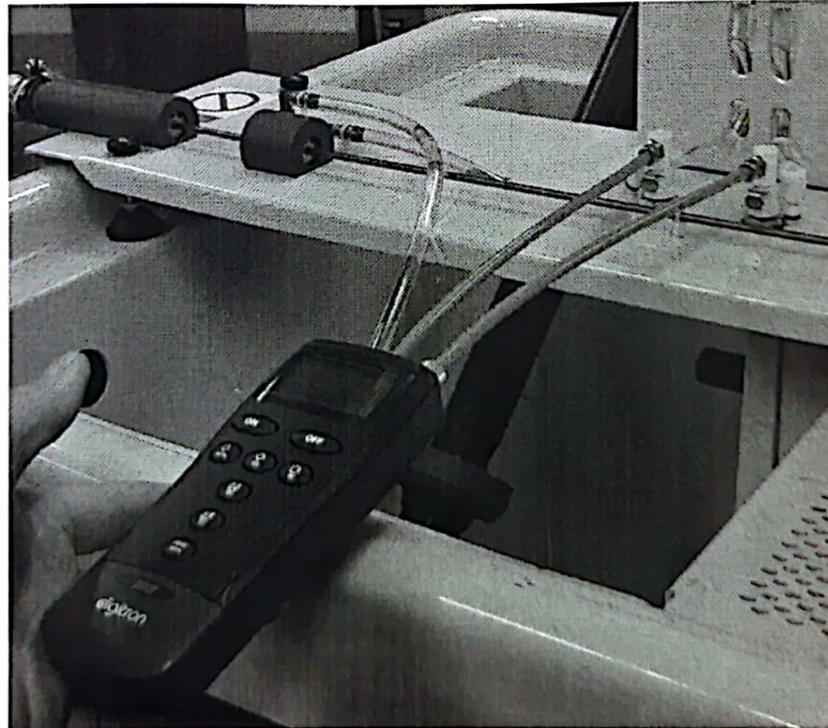

Figure 14 Keep the Meter Level

8. Adjust the Hydraulic Bench supply valve until you have a pressure differential of around 2000 mm (2 m) of water.

9. Now follow procedure 1 but takes steps of around 0.2 m (200 mm) differential, giving more than 8 sets of readings. Stop taking results at a differential of around 0.4 m (400 mm).
10. After use, unplug the meter connections and switch off the meter. Gently shake out any trapped water from its measuring pipes and store the meter safely.

Results Analysis

Results Tables

For the lower flow results, find the head differences (h_1-h_2). For the higher flow results, the meter does this for you automatically. Write the result in metres in the Δh column.

For each line of your results, calculate the volume flow in m^3/s then use this with the cross-sectional area to find the flow velocity u .

For all results, find the water viscosity using your recorded temperature and the values given in Table 2. Also calculate the hydraulic gradient i (see **To Find Hydraulic Gradient (i)** on page 21) then find $\log i$ and $\log u$.

Use the Darcy equation (18) to find the friction factor (f) and Equation 3 to find the Reynolds number (Re). For the Reynolds number, as long as your water temperature is around $20^\circ C$, you may assume that water density is 1000 kg.m^{-3} .

Charts

From both sets of results plot charts of hydraulic gradient (vertical axis) against flow velocity (horizontal axis), similar to Figure 15.

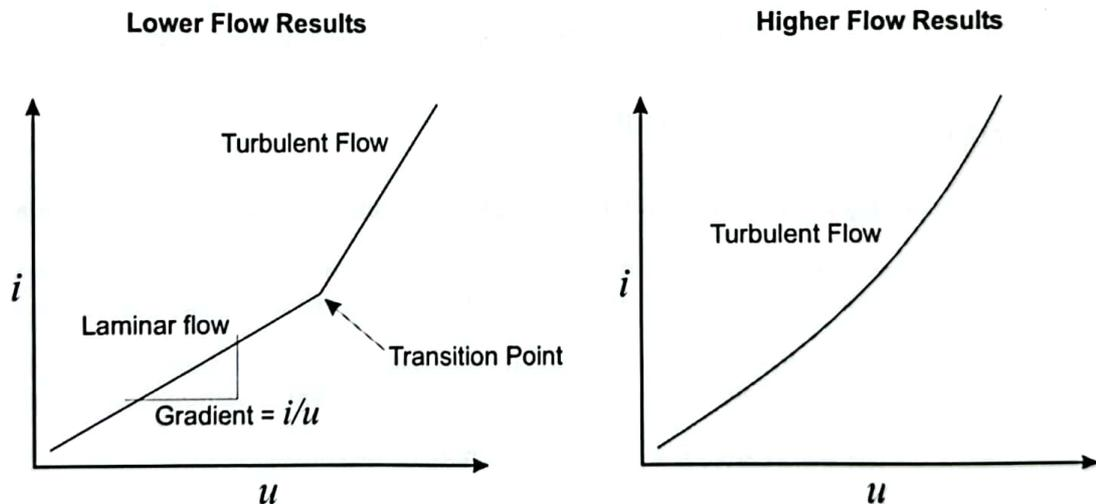

Figure 15 Typical Results

From your lower flow results chart you should see a distinct transition point from the laminar and linear area to a steeper (higher gradient) area of turbulent flow. Note the calculated Reynolds' numbers around this transition point. Do they match the theory?

The lower flow chart should prove the proportional relationship between i and u for laminar flow and therefore how frictional loss is proportional to velocity in the laminar flow region.

Find the gradient (i/u) for the laminar flow area of the lower flow results and use this value with Equation 1 to check the theoretical water viscosity against the value you found from your recorded temperature and the given tables. This should help prove Poiseuille's equation for laminar flow.

From your higher flow results, plot a chart of $\log i$ (vertical axis) against $\log u$ (horizontal axis).

Pick some results in the turbulent region and use the Blasius equation (20) to find the friction factor. Compare your answers with those found from the Darcy equation.

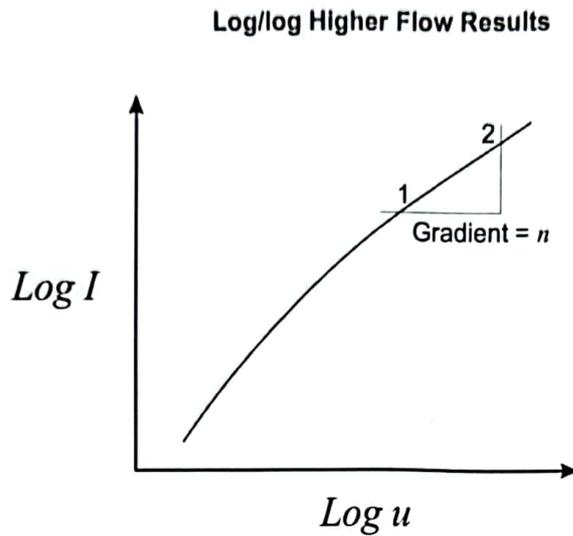

Figure 16 Typical Log/Log Results

From your log/log results, find the gradient (n) over the most linear part. Figure 16 shows this as a region between points 1 and 2. From this result, you can say that (from Equation 7):

$$i \propto u^n \text{ across the flow range between points 1 and 2.}$$

Errors

Can you identify any causes of error in your experiments and how they would affect the results?

Typical Results

All results are for reference only. Actual results may differ slightly.

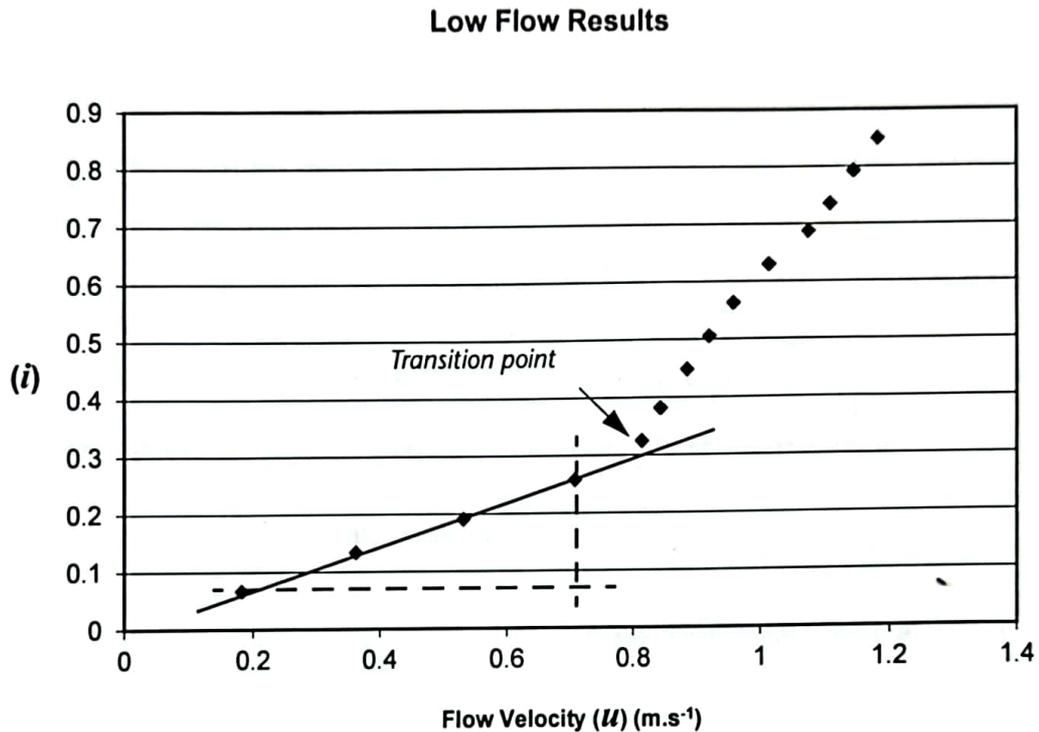

Figure 17 Typical Low Flow Results

The typical low flow results are reasonably linear until the flow reaches just over $0.8 \text{ m}\cdot\text{s}^{-1}$, when it reaches the transition point. The results then become steeper as the flow enters the turbulent region.

The calculated Reynolds number at the transition point is roughly 2373. It is less for lower flow velocity and reaches approximately 3440 at the highest flow possible with the header tank.

The i/u gradient gives approximately $(0.26-0.07)/(0.7-0.18) = 0.19/0.52 = 0.37$.

From Equation 1:

For $\rho = 1000$, $g = 9.81$ and $D^2 = 0.003^2$,

$0.37 \times (1000 \times 9.81 \times 0.003^2)/32 = (0.37 \times 0.08829)/32 = 0.00102 \text{ Pa}\cdot\text{s}$ (1.02 mPa.s)

From Table 2, this is for a temperature of around 19°C . This compares exactly with the measured test temperature of 19°C and shows that Poiseuille's equation seems to work.

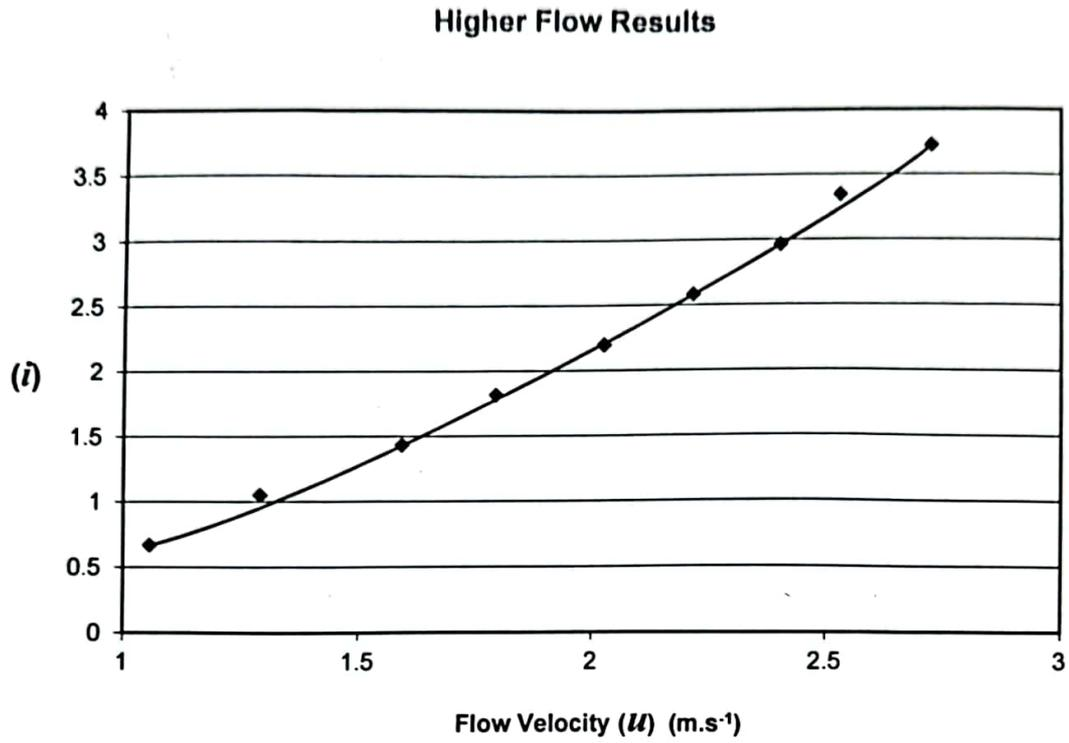

Figure 18 Typical Higher Flow Results

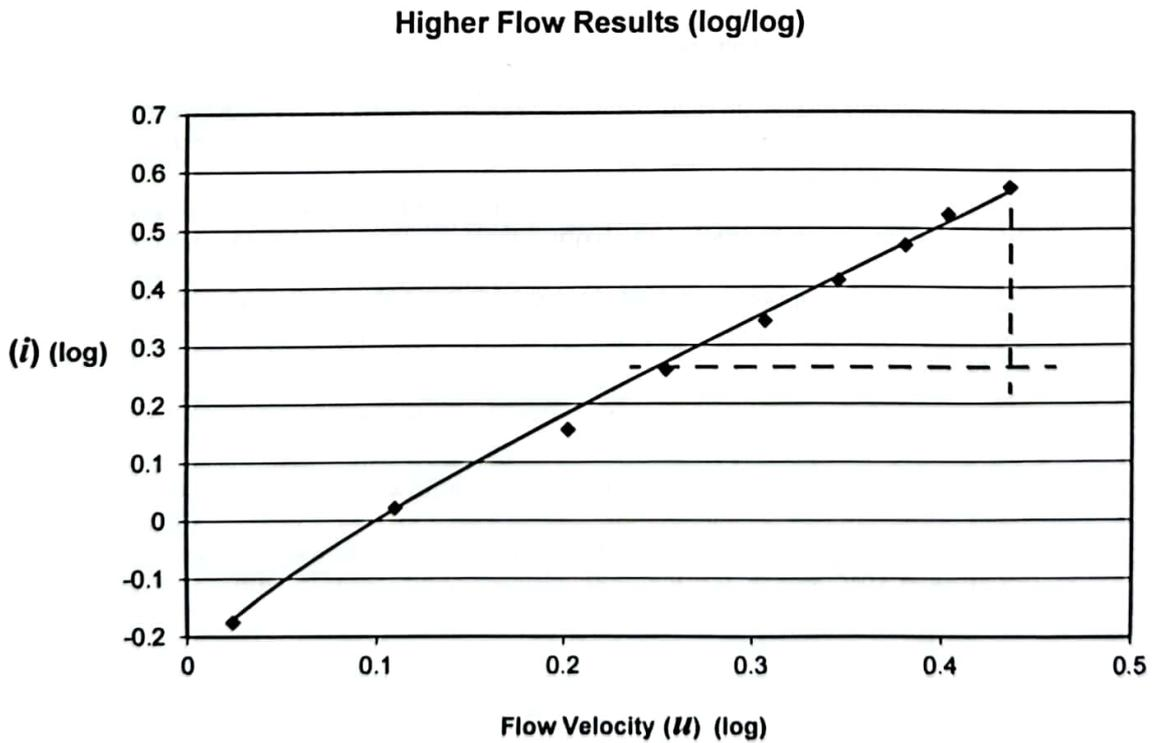

Figure 19 Higher Flow Results Log/Log

From the higher flow results, the highest six points give a reasonably linear section, with a gradient of roughly $(0.56-0.26)/(0.43-0.25) = 0.3/0.18 = 1.7$.

Therefore, for the turbulent flow results, the gradient is around 1.7 for a value of u between 1.79 and 2.72 $\text{m}\cdot\text{s}^{-1}$. This confirms the prediction for Equation 19 shown in the theory.

Picking a turbulent (higher) flow rate of 1.79 $\text{m}\cdot\text{s}^{-1}$, giving a Reynolds number of 5227, the Blasius number from Equation 20 will then be $0.079 \times 5227^{-0.25} = 0.0093$, which compares reasonably well with the calculated Darcy friction factor of 0.0083.

The comparison will not work so well for higher flow rates, with higher Reynolds numbers of around 7000 upwards.

The main causes of error will be in the reading of the water manometer. The water manometer is a simple, direct reading, fundamental instrument, but you can make slight errors in reading the levels - due to the slight meniscus at the top of the water in the tubes.

Also, the internal diameter of the test pipe is important. Even variations of 0.1 mm in diameter will greatly affect the calculations of Reynolds number and therefore friction factor.

To improve your results, rather than use the nominal value, you could use an accurate instrument to measure the internal diameter of the sample test pipe (supplied with the equipment), then use this new value in your calculations. You could also repeat the higher flow results with both increasing and decreasing flow and find an average value of head.

Maintenance, Spare Parts and Customer Care

Maintenance

Regularly check all parts of the apparatus for damage, renew if necessary.

When not in use, store the apparatus in a dry, dust-free area, covered with a plastic sheet. If the apparatus becomes dirty, wipe the surfaces with a damp, clean cloth. Do not use abrasive cleaners.

Regularly check all fixings and fastenings for tightness, adjust where necessary.



Renew faulty or damaged parts with an equivalent item of the same type or rating.

Checking the Air Valve and Water Manometer Circuit

1. Connect the water manometer.
2. Allow a nominal flow of water through the apparatus. Lightly tap the manometer tubes to clear air from the circuit.
3. Increase the water flow to give a maximum scale reading. Look at these levels and check that they remain steady. If they slowly rise, check the air valve in the small chamber at the top of the manometer. Make sure it is tight and sealed properly. If tightening does not stop the leak, replace the valve seal.

Spare Parts

Check the Packing Contents List to see what spare parts we send with the apparatus.

If you need technical help or spares, please contact your local TecQuipment agent, or contact TecQuipment direct.

When you ask for spares, please tell us:

- Your name
- The full name and address of your college, company or institution
- Your email address
- The TecQuipment product name and product reference
- The TecQuipment part number (if you know it)
- The serial number
- The year it was bought (if you know it)

Please give us as much detail as possible about the parts you need and check the details carefully before you contact us.

If the product is out of warranty, TecQuipment will let you know the price of the spare parts.

Customer Care

We hope you like our products and manuals. If you have any questions, please contact our Customer Care department:

Telephone: +44 115 954 0155

Fax: +44 115 973 1520

Email: customer.care@tecquipment.com

For information about all TecQuipment products visit: www.tecquipment.com

Air Valves

TecQuipment's
Fluid Mechanics Products
Instruction Sheets

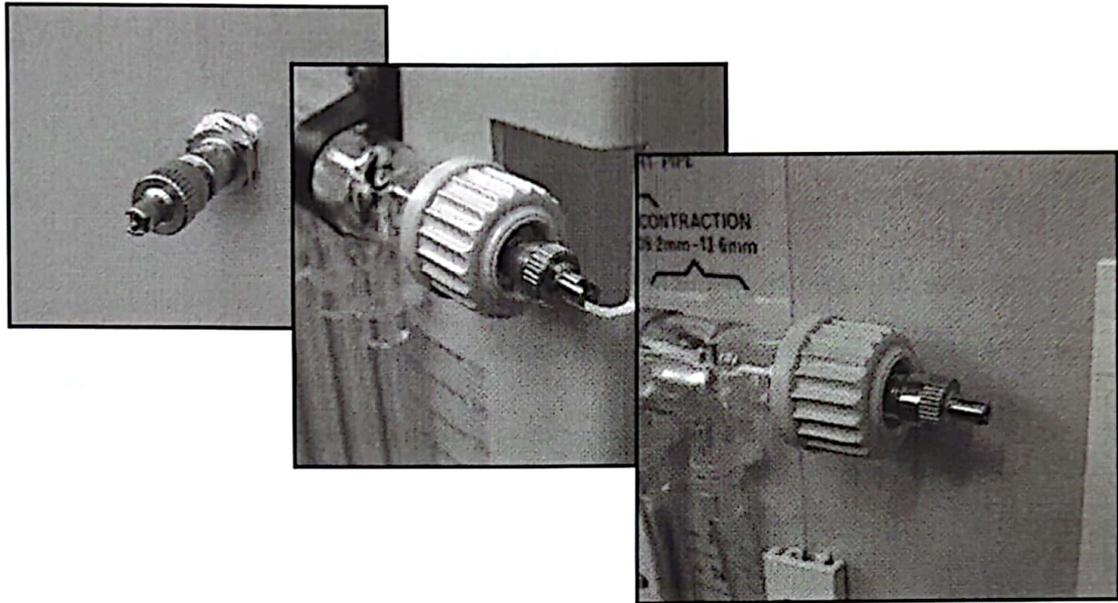

Figure 20 Typical Air Valves on Some of TecQuipment's Products

Many of the products in TecQuipment's Fluid Mechanics range use air valves at the tops of manometers or piezometers. The valves keep the air in the manometer tubes to allow you to offset the pressure range of the manometer or piezometer.

The valves are similar to valves used in vehicle tyres and include a special cap. The hand pump supplied with the equipment is similar to those used for bicycle tyres, except that TecQuipment remove the cross-shape part of the flexible pipe.

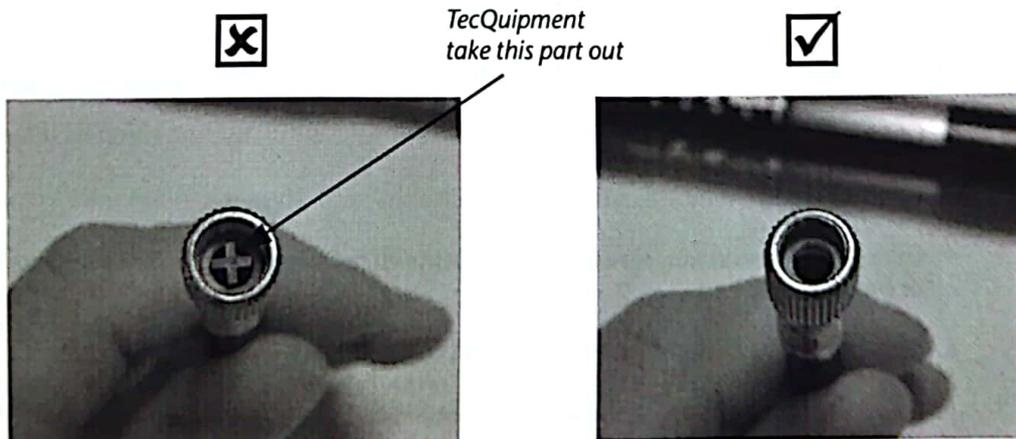

Figure 21 TecQuipment Remove the Cross-shape Part of the Flexible Pipe

Normally, when you connect the flexible pipe to an air valve, the cross-shape piece in the flexible pipe pushes open the valve as you pump air with the hand pump. With TecEquipment fluid mechanics products, this could allow water back out through the valve. For this reason TecEquipment remove the cross-shape piece. Without the cross-shape piece, only pressurised air can go through the valve in one direction, and no water can come back out.



Figure 22 The Hand Pump and Flexible Pipe

When you first use the hand pump with the air valve, you may find it hard to push air through the valve. This is because the valve is new and you do not have the cross-shape piece to help push it open. The valve will open more easily after you have pumped air through it a few times.

You may need some practice to use the air valve. To do it correctly:

1. Unscrew the cap from the valve.

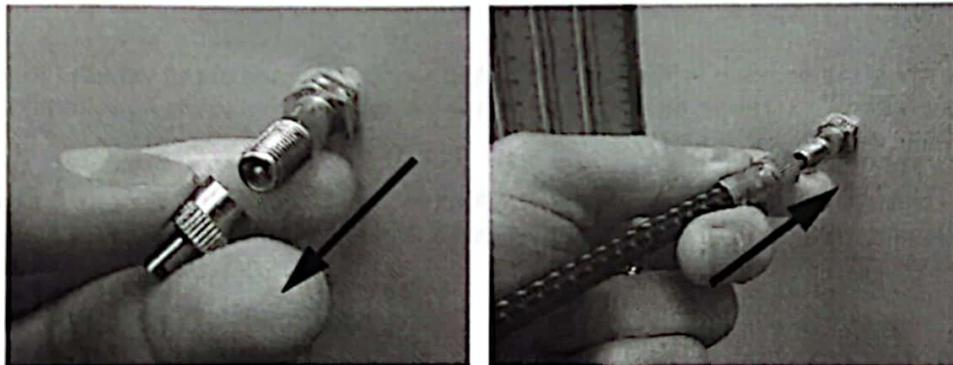

Figure 23 Unscrew the Cap and Fit the Pipe

2. Connect the flexible pipe to the valve.
3. Connect the hand pump to the flexible pipe.
4. Using complete strokes, **slowly and firmly** pump the hand pump to force air into the manometer or piezometer.
5. Unscrew the hand pump and flexible pipe and refit the valve cover.
6. To let air back out through the air valve, use the end of the special cap to press on the inner part of the valve (see Figure 24).

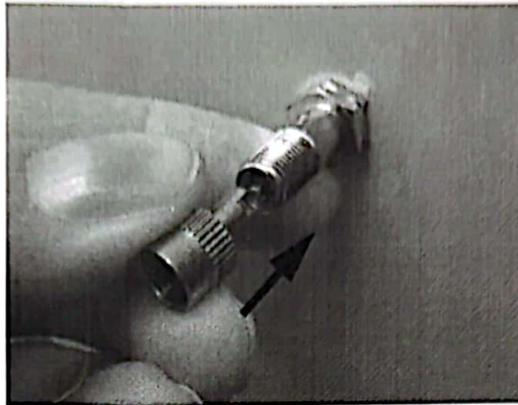

Figure 24 To Let Air Out - Use the End of the Special Cap to Press the Inner Part of the Valve

WARNING



Take care when you let air back out from the air valve. Water may come out!

Clean up any water spills immediately.

If using the hand pump is too difficult, the valve may be stuck. If you need to check the valve is working, use the special cap to unscrew the valve, then gently press the end of the valve. It should move easily and return back to its original position (see Figure 25).

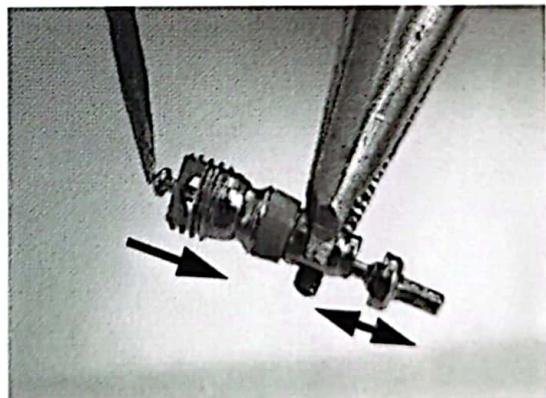

Figure 25 Unscrew the Valve and Check it

If the valve does not move easily, then contact TecEquipment Customer Services for help.

Telephone: +44 115 9722611

Fax: +44 115 973 1520

Email: customer.care@tecquipment.com

TecEquipment 0809 DB